

IPG-8901609-8901615

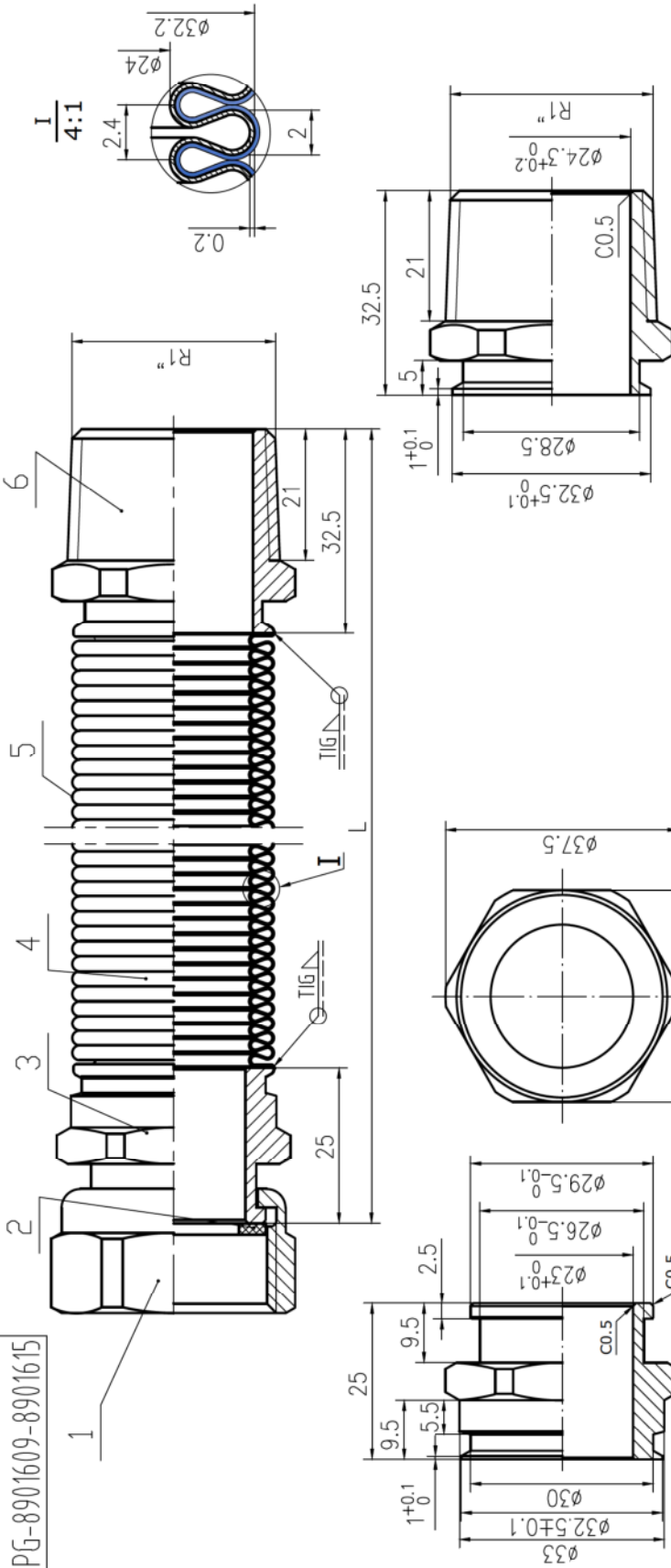

Technical requirement :

1. Annealing and compression after hose body with cover
2. weld joint to be uniform
3. No scratches or other defects on the surface of the hose
4. Wave uniformity
5. Working pressure 3Bar
6. Working temperature: Max 110°C

6	TZX-201-25-1	Male	1	ASTM304		
5	TZX-404-14-35	heat shrink tube	1	PE		
4	TZX-001-320-1	Metal hose	1	ASTM316L		$\phi 32 \times 0.2$
3	TZX-308-25-1	Joint	1	ASTM304		
2	TZX-401-25-1	Gaskets	1	NBR		$\phi 30.5 \times \phi 21 \times 3$
1	TZX-101-25-1	Nut	1	ASTM304		
No.	Code	Name	QTY.	Material	Remarks	

IPG			
designed	weight	scale	
checked			1:5:1
approved	Sheet		
1" MF PVC COVER			
IPG-8901609-8901615			

CODE	8901609	8901610	8901611	8901612	8901613	8901614	8901615
L	75/91	110/160	200/320	260/450	500/900	750/1400	1000/1900