

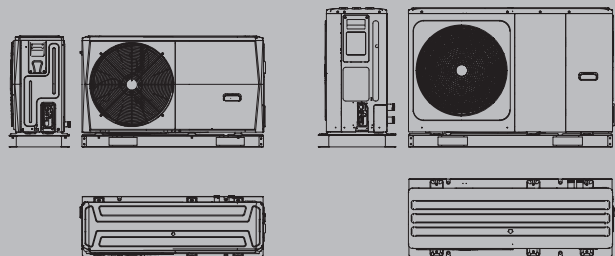

NXHM 004-016

Monobloc air-water heat pumps

Reversible air-water "quiet operation" heat pump with helicoidal fans 4 kW - 16 kW, with R32 ecological refrigerant



HEAT PUMPS

Air-water heat pumps

NXHM 004-016

PRODUCT DESCRIPTION

NXHM is a high-efficiency residential hydronic heat pump for heating and cooling, with the possibility of domestic hot water production for domestic use.

The unit works with R32 ecological refrigerant, guaranteeing not only low global warming potential (GWP) and low CO₂ emissions, but also optimum energy efficiency over the whole operating range.

NXHM is also fitted with new exchange coils with the special hydrophilic and anti-corrosion Blue-Fin treatment that improves the drainage of condensate on the fins, thereby reducing the risk of the coils freezing (maximum efficiency even in damp climates).

NXHM comes in 10 different models with a heating capacity from 4.2 to 15.9 kW.

- Twin rotary compressor with DC inverter technology, that modulates the output to adapt perfectly to the real load needed.
- High COP and EER values (all the NXHM heat pumps comply with the highest standards requested in terms of energy efficiency).
- Performance ratings certified by the third party body HP Keymark.
- They can be connected to low-temperature radiators, radiant floor elements and fan coil type units.
- Water heating temperature up to +65°C.
- Easy, quick installation.
- Low unit noise level.
- Wired control panel included, for the complete management of a heating/cooling/DHW system.
- The control panel can manage up to 6 units (even of different output levels) in cascade format - 1 master and 5 slaves.
- Anti-freeze protection as standard, to protect the entire system - in particular the hydraulic parts - from the potential damage caused by freezing.

TECHNICAL DATA NXHM 004-010

	Model	UM	NXHM 004	NXHM 006	NXHM 008	NXHM 010
PERFORMANCE DATA IN HEATING						
Performance in heating (A7°C; W35°C)						
	Nominal capacity	kW	4.20	6.35	8.40	10.00
	Input power	kW	0.82	1.28	1.63	2.02
	COP		5.10	4.95	5.15	4.95
	SCOP (temperate zone)		4.85	4.95	5.22	5.20
	Seasonal energy efficiency	%	191	195	206	205
	Energy class		A+++	A+++	A+++	A+++
Performance in heating (A7°C; W45°C)						
	Nominal capacity	kW	4.30	6.30	8.10	10.00
	Input power	kW	1.13	1.70	2.10	2.67
	COP		3.80	3.70	3.85	3.75
Performance in heating (A7°C; W55°C)						
	Nominal capacity	kW	4.40	6.00	7.50	9.50
	Input power	kW	1.49	2.03	2.36	3.06
	COP		2.95	2.95	3.18	3.10
	SCOP (temperate zone)		3.31	3.52	3.37	3.47
	Seasonal energy efficiency	%	130	139	133	137
	Energy class		A++	A++	A++	A++
PERFORMANCE DATA IN COOLING						
Performance in cooling (A35°C; W7°C)						
	Nominal capacity	kW	4.70	7.00	7.45	8.20
	Input power	kW	1.36	2.33	2.22	2.52
	EER		3.45	3.00	3.35	3.25
	SEER		4.99	5.34	5.83	5.99
	Seasonal energy efficiency	%	196	210	230	236

	Model	UM	NXHM 004	NXHM 006	NXHM 008	NXHM 010
Performance in cooling (A35°C; W18°C)						
Nominal capacity	kW		4.50	6.50	8.30	9.90
Input power	kW		0.82	1.35	1.64	2.18
EER			5.50	4.80	5.05	4.55
ELECTRICAL CHARACTERISTICS						
Electrical supply	V/ph/Hz		230/1/50	230/1/50	230/1/50	230/1/50
Total maximum input power (1)	kW		2.30	2.70	3.40	3.70
Total maximum input current (2)	A		12.00	14.00	16.00	17.00
COMPRESSOR						
Compressor	Type/ brand		DC twin rotary/ Mitsubishi	DC twin rotary/ Mitsubishi	DC twin rotary/ Mitsubishi	DC twin rotary/ Mitsubishi
Adjustment	Type		Inverter modulating	Inverter modulating	Inverter modulating	Inverter modulating
Minimum capacity control	%		55	43	40	38
Refrigerant	Type		R32	R32	R32	R32
GWP	CO2 equiv. in t/kg		675	675	675	675
Refrigerant load	kg		1.40	1.40	1.40	1.40
Control box load	CO2 equiv. in t		0.95	0.95	0.95	0.95
Number of circuits	no.		1	1	1	1
Hermetically sealed control box (EU reg. 517_2014)	yes/no		yes	yes	yes	yes
FAN						
Fan	Type		DC axial	DC axial	DC axial	DC axial
Quantity	no.		1	1	1	1
Maximum air flow rate	m³/h		2770	2770	4030	4030
HEAT EXCHANGER (SOURCE SIDE)						
Heat exchanger (source side)	Type		Pipes in copper. fins in hydrophilic aluminium with anti-corrosion treatment	Pipes in copper. fins in hydrophilic aluminium with anti-corrosion treatment	Pipes in copper. fins in hydrophilic aluminium with anti-corrosion treatment	Pipes in copper. fins in hydrophilic aluminium with anti-corrosion treatment
CIRCULATION PUMP						
Circulation pump	Type		Variable speed centrifuge - model Para 25/9 IPWM- 130-1	Variable speed centrifuge - model Para 25/9 IPWM- 130-1	Variable speed centrifuge - model Para 25/9 IPWM- 130-1	Variable speed centrifuge - model Para 25/9 IPWM- 130-1
Nominal delivery	m³/h		0.72	1.09	1.44	1.72
Maximum operating pressure	bar		3	3	3	3
Maximum input power	kW		0.043	0.043	0.043	0.043
Maximum input current	A		0.44	0.44	0.44	0.44
Expansion tank volume	l		8.00	8.00	8.00	8.00
HEAT EXCHANGER (SYSTEM SIDE)						
Heat exchanger (system side)	Type		Plate. in stainless steel	Plate. in stainless steel	Plate. in stainless steel	Plate. in stainless steel
Water content	l		2.16	2.16	2.44	2.44
SOUND DATA						
Sound output (3)	dB(A)		55	58	59	60
Sound pressure at 1m (4)	dB(A)		45	47.5	48.5	50.5
WEIGHT						
Net weight	kg		98	98	121	121

The performance values comply with Standards UNI EN 14511:2018 and UNI EN 14825:2016. Performance data certified by HP Keymark.

(1) Input power from compressors and from fans and circulator in the maximum operating conditions, with the nominal power supply voltage.

(2) Maximum unit operating current with the nominal power supply voltage.

(3) Sound emission values declared, in accordance with standard EN 12102-1.

(4) Measured in a semi-anechoic chamber, at a distance of 1m from the front of the unit and a height from the floor equal to (1+H)/2, where H is the height of the unit expressed in metres (in accordance with standard EN 12102-1).

The data in the grey boxes are to be used for the telematic mailing to ENEA for tax relief purposes.

The data in the grey boxes are to be used for the registration of the control box in the F-GAS databank.

HEAT PUMPS

Air-water heat pumps

TECHNICAL DATA NXHM 012-016

		Model	UM	NXHM 012	NXHM 014	NXHM 016	NXHM 012T	NXHM 014T	NXHM 016T
PERFORMANCE DATA IN HEATING									
Performance in heating (A7°C; W35°C)									
	Nominal capacity	kW		12.10	14.50	15.90	12.10	14.50	15.90
	Input power	kW		2.44	3.15	3.53	2.44	3.15	3.53
	COP			4.95	4.60	4.50	4.95	4.60	4.50
	SCOP (temperate zone)			4.81	4.72	4.62	4.81	4.72	4.62
	Seasonal energy efficiency	%		189	186	182	189	186	182
	Energy class			A+++	A+++	A+++	A+++	A+++	A+++
Performance in heating (A7°C; W45°C)									
	Nominal capacity	kW		12.30	14.10	16.00	12.30	14.10	16.00
	Input power	kW		3.32	3.92	4.57	3.32	3.92	4.57
	COP			3.70	3.60	3.50	3.70	3.60	3.50
Performance in heating (A7°C; W55°C)									
	Nominal capacity	kW		11.90	13.80	16.00	11.90	13.80	16.00
	Input power	kW		3.90	4.68	5.61	3.90	4.68	5.61
	COP			3.05	2.95	2.85	3.05	2.95	2.85
	SCOP (temperate zone)			3.45	3.47	3.41	3.45	3.47	3.41
	Seasonal energy efficiency	%		136	137	134	136	137	134
	Energy class			A++	A++	A++	A++	A++	A++
PERFORMANCE DATA IN COOLING									
Performance in cooling (A35°C; W7°C)									
	Nominal capacity	kW		11.50	12.40	14.00	11.50	12.40	14.00
	Input power	kW		4.18	4.96	5.60	4.18	4.96	5.60
	EER			2.75	2.50	2.50	2.75	2.50	2.50
	SEER			4.89	4.86	4.69	4.86	4.83	4.67
	Seasonal energy efficiency	%		193	191	185	191	190	184
Performance in cooling (A35°C; W18°C)									
	Nominal capacity	kW		12.00	13.50	14.20	12.00	13.50	14.20
	Input power	kW		3.04	3.75	4.38	3.04	3.75	4.38
	EER			3.95	3.61	3.61	3.95	3.61	3.61
ELECTRICAL CHARACTERISTICS									
	Electrical supply	V/ph/Hz		230/1/50	230/1/50	230/1/50	400/3/50	400/3/50	400/3/50
	Total maximum input power (1)	kW		5.50	5.80	6.20	5.50	5.80	6.20
	Total maximum input current (2)	A		25.00	26.00	27.00	10.00	11.00	12.00
COMPRESSOR									
	Compressor	Type/brand		DC twin rotary/ Mitsubishi	DC twin rotary/ Mitsubishi	DC twin rotary/ Mitsubishi	DC twin rotary/ Mitsubishi	DC twin rotary/ Mitsubishi	DC twin rotary/ Mitsubishi
	Adjustment	Type		Inverter modulating	Inverter modulating	Inverter modulating	Inverter modulating	Inverter modulating	Inverter modulating
	Minimum capacity control	%		46	41	40	46	41	40
	Refrigerant	Type		R32	R32	R32	R32	R32	R32
	GWP	CO ₂ equiv. in t/kg		675	675	675	675	675	675
	Refrigerant load	kg		1.75	1.75	1.75	1.75	1.75	1.75
	Control box load	CO ₂ equiv. in t		1.18	1.18	1.18	1.18	1.18	1.18
	Number of circuits	no.		1	1	1	1	1	1
	Hermetically sealed control box (EU reg. 517_2014)	yes/no		yes	yes	yes	yes	yes	yes
FAN									
	Fan	Type		DC axial	DC axial	DC axial	DC axial	DC axial	DC axial
	Quantity	no.		1	1	1	1	1	1
	Maximum air flow rate	m ³ /h		4060	4060	4650	4060	4060	4650

	Model	UM	NXHM 012	NXHM 014	NXHM 016	NXHM 012T	NXHM 014T	NXHM 016T
HEAT EXCHANGER (SOURCE SIDE)								
Heat exchanger (source side)	Type		Pipes in copper fins in hydrophilic aluminium with anti-corrosion treatment	Pipes in copper fins in hydrophilic aluminium with anti-corrosion treatment	Pipes in copper fins in hydrophilic aluminium with anti-corrosion treatment	Pipes in copper fins in hydrophilic aluminium with anti-corrosion treatment	Pipes in copper fins in hydrophilic aluminium with anti-corrosion treatment	Pipes in copper fins in hydrophilic aluminium with anti-corrosion treatment
CIRCULATION PUMP								
Circulation pump	Type		Variable speed centrifuge - model Para 25/9 IPWM-130-1	Variable speed centrifuge - model Para 25/9 IPWM-130-1	Variable speed centrifuge - model Para 25/9 IPWM-130-1	Variable speed centrifuge - model Para 25/9 IPWM-130-1	Variable speed centrifuge - model Para 25/9 IPWM-130-1	Variable speed centrifuge - model Para 25/9 IPWM-130-1
Nominal delivery	m ³ /h		2.08	2.49	2.73	2.08	2.49	2.73
Maximum operating pressure	bar		3	3	3	3	3	3
Maximum input power	kW		0.043	0.043	0.043	0.043	0.043	0.043
Maximum input current	A		0.44	0.44	0.44	0.44	0.44	0.44
Expansion tank volume	l		8.00	8.00	8.00	8.00	8.00	8.00
HEAT EXCHANGER (SYSTEM SIDE)								
Heat exchanger (system side)	Type		Plate. in stainless steel	Plate. in stainless steel	Plate. in stainless steel	Plate. in stainless steel	Plate. in stainless steel	Plate. in stainless steel
Water content	l		2.78	2.78	2.78	2.78	2.78	2.78
SOUND DATA								
Sound output (3)	dB(A)		65	65	68	65	65	68
Sound pressure at 1m (4)	dB(A)		53	53.5	57.5	53.5	54	58
WEIGHT								
Net weight	kg		144	144	144	160	160	160

The performance values comply with Standards UNI EN 14511:2018 and UNI EN 14825:2016. Performance data certified by HP Keymark.

(1) Input power from compressors and from fans and circulator in the maximum operating conditions, with the nominal power supply voltage.

(2) Maximum unit operating current with the nominal power supply voltage.

(3) Sound emission values declared, in accordance with standard EN 12102-1.

(4) Measured in a semi-anechoic chamber, at a distance of 1m from the front of the unit and a height from the floor equal to (1+H)/2, where H is the height of the unit expressed in metres (in accordance with standard EN 12102-1).

 The data in the grey boxes are to be used for the telematic mailing to ENEA for tax relief purposes.

 The data in the grey boxes are to be used for the registration of the control box in the F-GAS databank.

HEAT PUMPS

Air-water heat pumps

TECHNICAL DATA ERP NXHM 004-010

Model	UM	NXHM 004	NXHM 006	NXHM 008	NXHM 010
Temperate zone - Low temperature (30/35°C) EU reg. 811_2013					
Seasonal energy efficiency	%	191	195	206	205
SCOP		4.85	4.95	5.22	5.20
Pdesignh at -7°C	kW	4.88	6.03	7.18	8.10
Energy class		A+++	A+++	A+++	A+++
Sound output	dB(A)	55	58	59	60
Temperate zone - Medium temperature (47/55°C) EU reg. 811_2013					
Seasonal energy efficiency	%	130	139	133	137
SCOP		3.31	3.52	3.37	3.47
Pdesignh at -7°C	kW	3.89	5.04	5.84	6.78
Energy class		A++	A++	A++	A++

The performance values comply with Standards UNI EN 14511:2018 and UNI EN 14825:2016.

TECHNICAL DATA ERP NXHM 012-016

Model	UM	NXHM 012	NXHM 014	NXHM 016	NXHM 012T	NXHM 014T	NXHM 016T
Temperate zone - Low temperature (30/35°C) EU reg. 811_2013							
Seasonal energy efficiency	%	189	186	182	189	186	182
SCOP		4.81	4.72	4.62	4.81	4.72	4.62
Pdesignh at -7°C	kW	10.61	12.14	13.45	10.61	12.14	13.45
Energy class		A+++	A+++	A+++	A+++	A+++	A+++
Sound output	dB(A)	65	65	68	65	65	68
Temperate zone - Medium temperature (47/55°C) EU reg. 811_2013							
Seasonal energy efficiency	%	136	137	134	136	137	134
SCOP		3.45	3.47	3.41	3.45	3.47	3.41
Pdesignh at -7°C	kW	10.24	10.68	11.52	10.24	10.68	11.52
Energy class		A++	A++	A++	A++	A++	A++

The performance values comply with Standards UNI EN 14511:2018 and UNI EN 14825:2016.

SOUND PRESSURE LEVEL

Model	UM	NXHM									
		004	006	008	010	012	014	016	012T	014T	016T
Sound pressure (1)	dB (2)	45	47,5	48,5	50,5	53	53,5	57,5	53,5	54	58

- (1) The sound pressure level is measured at a position 1 m in front of the unit and (1+H)/2 m (where H is the height of the unit) above the floor in a semi-anechoic chamber. During on-site operation, sound pressure levels may be higher due to ambient noise.
- (2) dB is the maximum value tested under the following conditions:
 Outdoor air temperature 7°C DB, 85% R.H.; EWT 30°C, LWT 35°C. Variable compressor frequency.
 Outdoor air temperature 7°C DB, 85% R.H.; EWT 47°C, LWT 55°C. Variable compressor frequency.

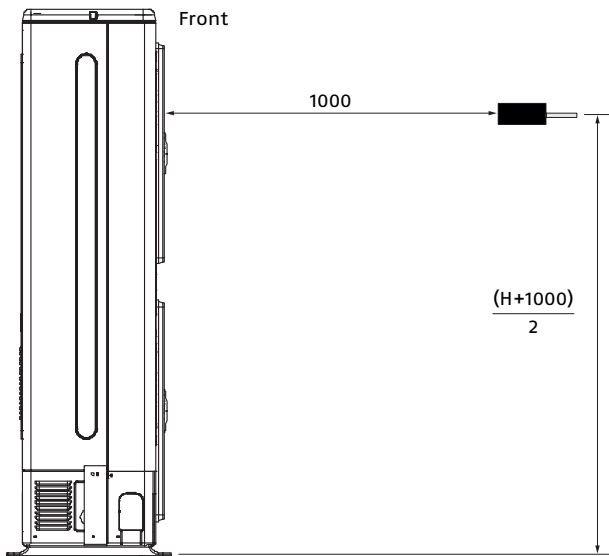

Unit of measurement: mm.

NXHM 004

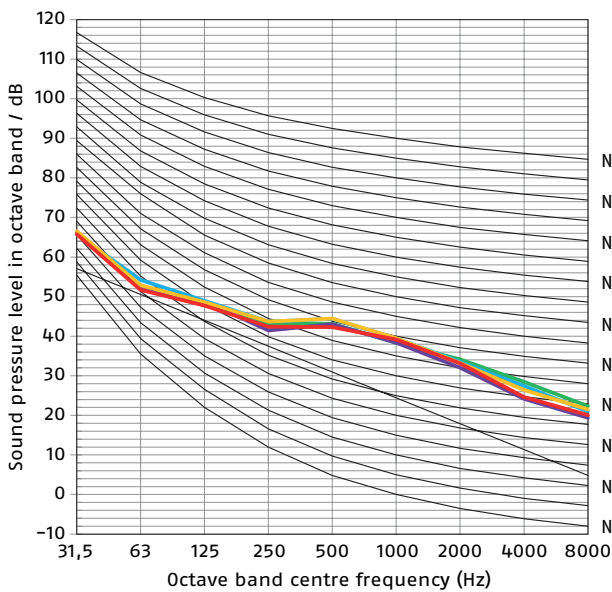

- Cooling at rated frequency
Outdoor air temperature 35°C dry bulb - Water inlet temperature 12°C - Water outlet temperature 7°C.
- Cooling at rated frequency
Outdoor air temperature 35°C dry bulb - Water inlet temperature 23°C - Water outlet temperature 18°C.
- Heating at rated frequency
Outdoor air temperature 7°C dry bulb - Relative humidity 85% - Water inlet temperature 30°C - Water outlet temperature 35°C.

NXHM 006

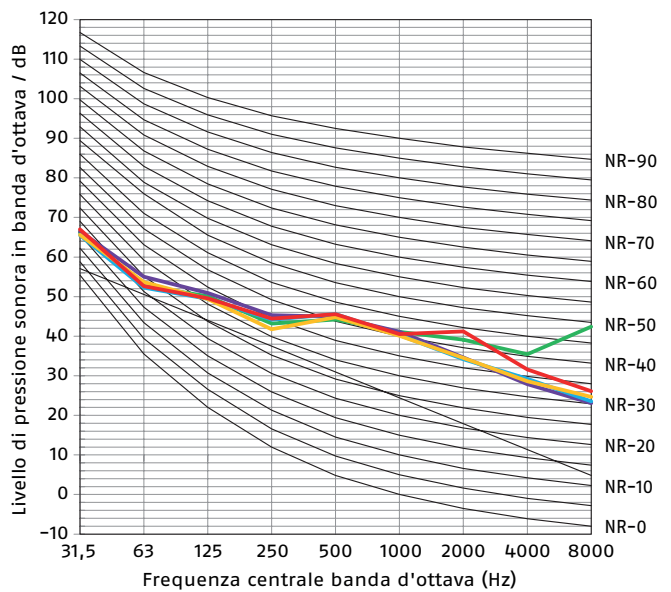

- Heating at rated frequency
Outdoor air temperature 7°C dry bulb - Relative humidity 85% - Water inlet temperature 40°C - Water outlet temperature 45°C.
- Heating at rated frequency
Outdoor air temperature 7°C dry bulb - Relative humidity 85% - Water inlet temperature 47°C - Water outlet temperature 55°C.

HEAT PUMPS

Air-water heat pumps

NXHM 008

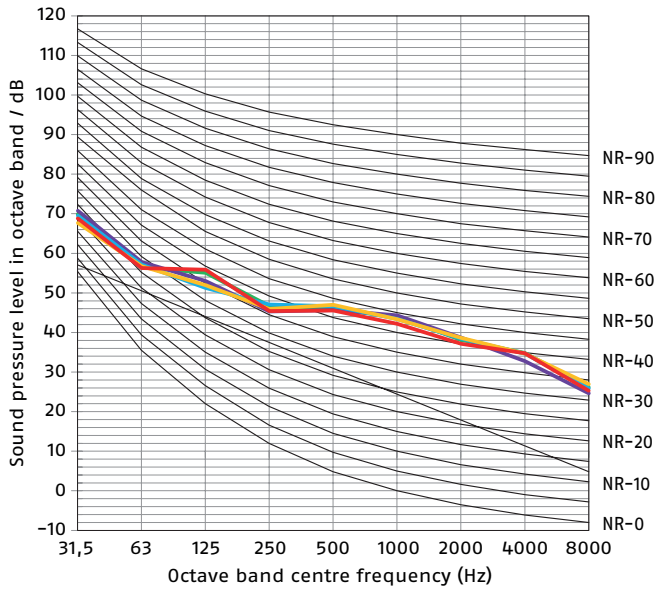

- Cooling at rated frequency
Outdoor air temperature 35°C dry bulb - Water inlet temperature 12°C - Water outlet temperature 7°C.
- Cooling at rated frequency
Outdoor air temperature 35°C dry bulb - Water inlet temperature 23°C - Water outlet temperature 18°C.
- Heating at rated frequency
Outdoor air temperature 7°C dry bulb - Relative humidity 85% - Water inlet temperature 30°C - Water outlet temperature 35°C.

NXHM 010

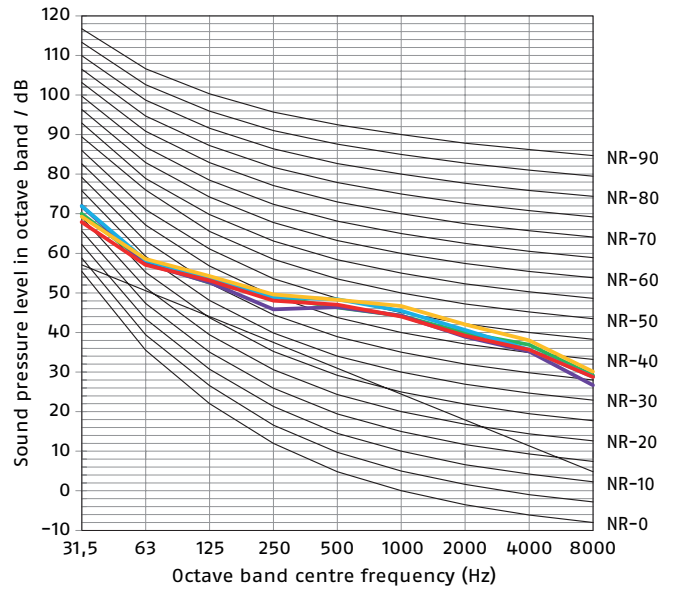

- Heating at rated frequency
Outdoor air temperature 7°C dry bulb - Relative humidity 85% - Water inlet temperature 40°C - Water outlet temperature 45°C.
- Heating at rated frequency
Outdoor air temperature 7°C dry bulb - Relative humidity 85% - Water inlet temperature 47°C - Water outlet temperature 55°C.

NXHM 012

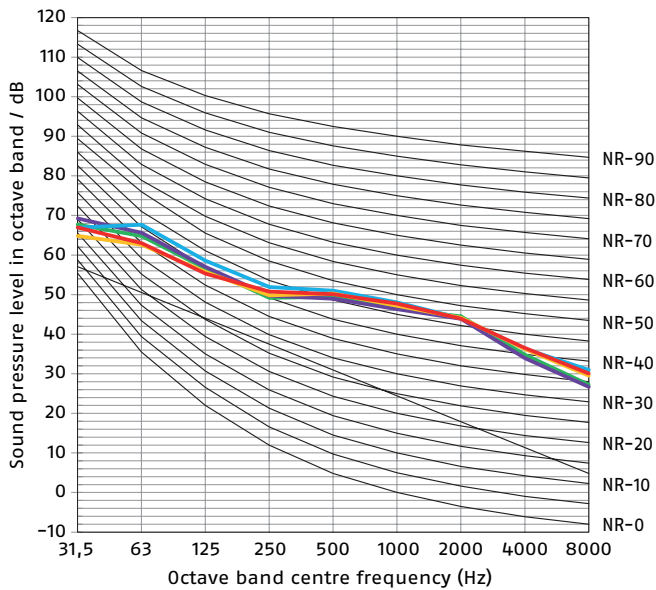

- Cooling at rated frequency
Outdoor air temperature 35°C dry bulb - Water inlet temperature 12°C - Water outlet temperature 7°C.
- Cooling at rated frequency
Outdoor air temperature 35°C dry bulb - Water inlet temperature 23°C - Water outlet temperature 18°C.
- Heating at rated frequency
Outdoor air temperature 7°C dry bulb - Relative humidity 85% - Water inlet temperature 30°C - Water outlet temperature 35°C.

NXHM 014

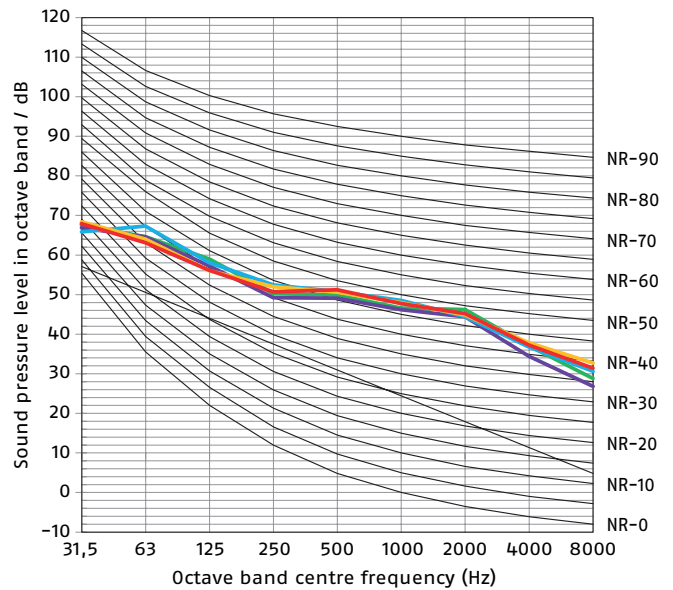

- Heating at rated frequency
Outdoor air temperature 7°C dry bulb - Relative humidity 85% - Water inlet temperature 40°C - Water outlet temperature 45°C.
- Heating at rated frequency
Outdoor air temperature 7°C dry bulb - Relative humidity 85% - Water inlet temperature 47°C - Water outlet temperature 55°C.

NXHM 016

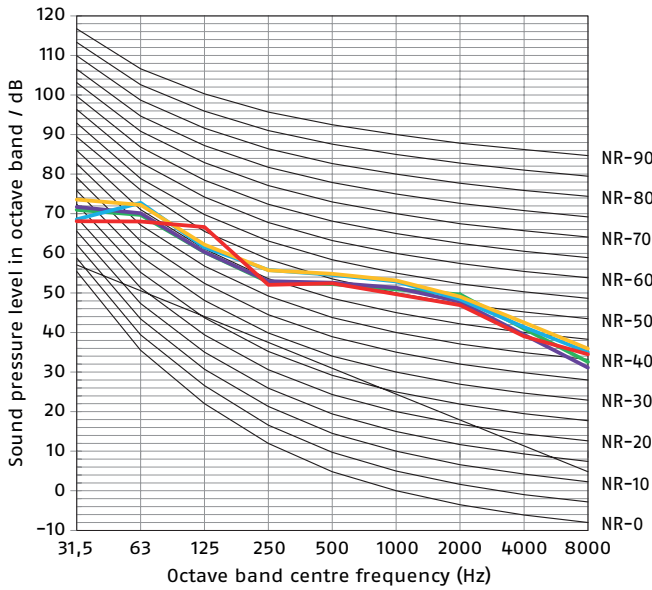

- Cooling at rated frequency
Outdoor air temperature 35°C dry bulb - Water inlet temperature 12°C - Water outlet temperature 7°C.
- Cooling at rated frequency
Outdoor air temperature 35°C dry bulb - Water inlet temperature 23°C - Water outlet temperature 18°C.
- Heating at rated frequency
Outdoor air temperature 7°C dry bulb - Relative humidity 85% - Water inlet temperature 30°C - Water outlet temperature 35°C.

NXHM 012T

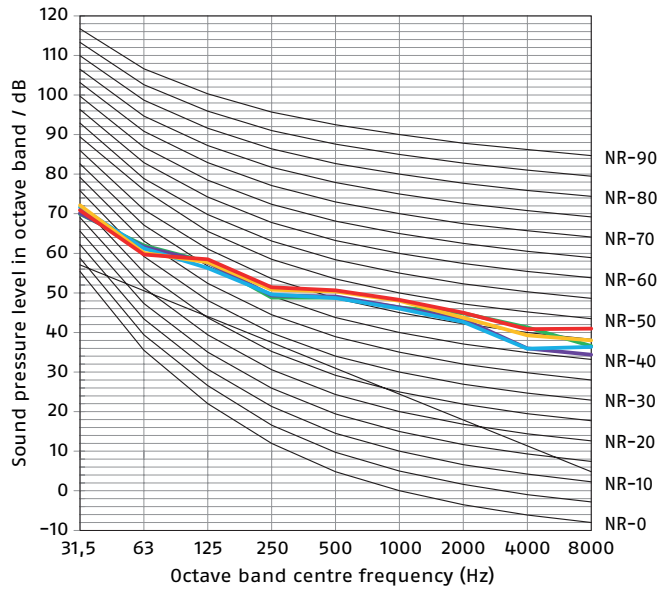

- Heating at rated frequency
Outdoor air temperature 7°C dry bulb - Relative humidity 85% - Water inlet temperature 40°C - Water outlet temperature 45°C.
- Heating at rated frequency
Outdoor air temperature 7°C dry bulb - Relative humidity 85% - Water inlet temperature 47°C - Water outlet temperature 55°C.

NXHM 014T

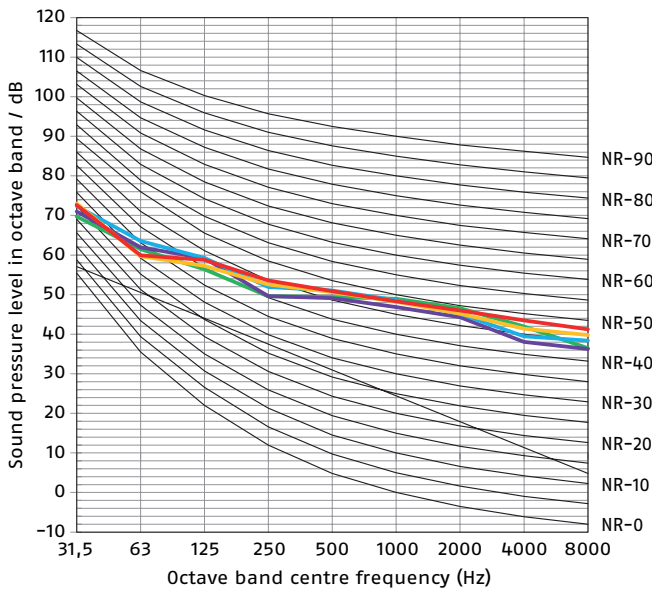

- Cooling at rated frequency
Outdoor air temperature 35°C dry bulb - Water inlet temperature 12°C - Water outlet temperature 7°C.
- Cooling at rated frequency
Outdoor air temperature 35°C dry bulb - Water inlet temperature 23°C - Water outlet temperature 18°C.
- Heating at rated frequency
Outdoor air temperature 7°C dry bulb - Relative humidity 85% - Water inlet temperature 30°C - Water outlet temperature 35°C.

NXHM 016T

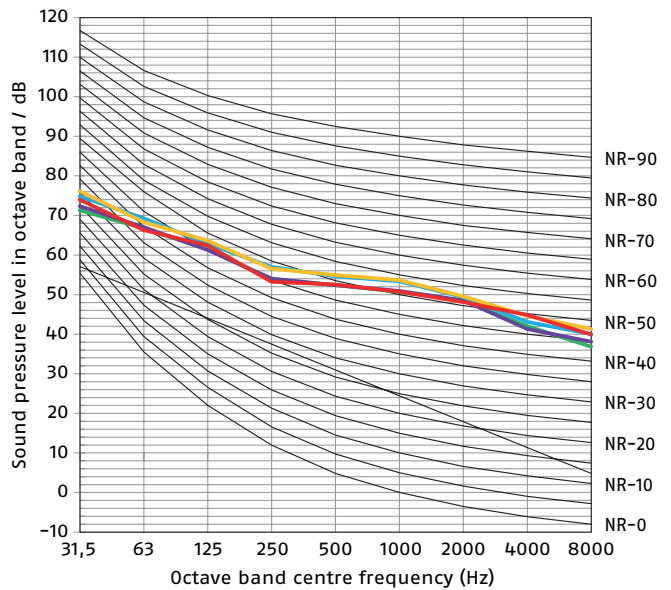

- Heating at rated frequency
Outdoor air temperature 7°C dry bulb - Relative humidity 85% - Water inlet temperature 40°C - Water outlet temperature 45°C.
- Heating at rated frequency
Outdoor air temperature 7°C dry bulb - Relative humidity 85% - Water inlet temperature 47°C - Water outlet temperature 55°C.

HEAT PUMPS

Air-water heat pumps

PERFORMANCE VALUES IN ACCORDANCE WITH STANDARDS EN 14511 and EN 14825

NXHM 004 - HEATING

Performance with full load						
Delivery temperature	35°C		45°C		55°C	
Outdoor temperature	Nominal capacity (kW)	COP	Nominal capacity (kW)	COP	Nominal capacity (kW)	COP
-7	4.70	3.10	4.30	2.35	4.00	1.95
2	4.40	4.00	5.10	3.00	5.10	2.45
7	4.20	5.10	4.30	3.80	4.40	2.95
12	5.26	5.61	5.59	4.22	4.98	3.38
15	5.14	4.84	5.67	4.37	4.96	3.53
20	5.09	5.46	5.63	4.88	4.89	3.84
35	5.54	7.89	5.70	6.47	5.14	4.92
Performance with partial load						
Tbival (-7°C)	A	B	C	D		
Outdoor temperature (°C)	-7	2	7	12		
PLR - Climate load factor	0.88	0.54	0.35	0.15		
DC - Output with full load	4.70	4.40	4.20	5.26		
COP with full load	3.10	4.00	5.10	5.61		
COP with partial load	3.10	4.78	6.13	8.05		
CR - Load factor	1.00	0.66	0.45	0.15		
f COP - Corrective factor	1.00	1.20	1.20	1.43		

NOTE: the performance values with a partial load refer to an output water temperature of 35°C.

NXHM 004 - COOLING

	Load factor	Outdoor temperature (°C)	EER
EER1	100%	35	3.45
EER2	75%	30	4.76
EER3	50%	25	5.72
EER4	25%	20	5.72

NXHM 006 - HEATING

Performance with full load						
Delivery temperature	35°C		45°C		55°C	
Outdoor temperature	Nominal capacity (kW)	COP	Nominal capacity (kW)	COP	Nominal capacity (kW)	COP
-7	6.00	3.00	5.40	2.40	5.15	2.00
2	5.50	3.90	5.80	3.00	5.65	2.45
7	6.35	4.95	6.30	3.70	6.00	2.95
12	6.51	5.38	6.83	4.09	6.12	3.27
15	6.48	5.57	6.98	4.32	6.15	3.42
20	6.27	6.28	6.82	4.62	6.03	3.76
35	6.46	8.87	6.55	5.79	6.02	4.75
Performance with partial load						
Tbival (-7°C)	A	B	C	D		
Outdoor temperature (°C)	-7	2	7	12		
PLR - Climate load factor	0.88	0.54	0.35	0.15		
DC - Output with full load	6.00	5.50	6.35	6.51		
COP with full load	3.00	3.90	4.95	5.38		
COP with partial load	3.00	4.85	6.63	7.93		
CR - Load factor	1.00	0.67	0.38	0.16		
f COP - Corrective factor	1.00	1.24	1.34	1.47		

NOTE: the performance values with a partial load refer to an output water temperature of 35°C.

NXHM 006 - COOLING

	Load factor	Outdoor temperature (°C)	EER
EER1	100%	35	3.00
EER2	75%	30	4.00
EER3	50%	25	6.45
EER4	25%	20	7.73

NXHM 008 - HEATING

Performance with full load						
Delivery temperature	35°C		45°C		55°C	
Outdoor temperature	Nominal capacity (kW)	COP	Nominal capacity (kW)	COP	Nominal capacity (kW)	COP
-7	7.00	3.20	6.60	2.55	6.15	2.05
2	7.10	4.10	7.40	3.25	7.10	2.60
7	8.40	5.15	8.10	3.85	7.50	3.18
12	8.03	5.99	8.06	4.26	7.26	3.54
15	8.11	6.37	8.15	4.55	7.33	3.68
20	8.37	7.53	8.36	5.25	7.47	4.14
35	7.89	8.74	8.83	6.77	7.48	5.03
Performance with partial load						
Tbival (-7°C)	A	B	C	D		
Outdoor temperature (°C)	-7	2	7	12		
PLR - Climate load factor	0.88	0.54	0.35	0.15		
DC - Output with full load	7.00	7.10	8.40	8.03		
COP with full load	3.20	4.10	5.15	5.99		
COP with partial load	3.20	5.09	6.82	8.35		
CR - Load factor	1.00	0.60	0.33	0.15		
f COP - Corrective factor	1.00	1.24	1.32	1.39		

NOTE: the performance values with a partial load refer to an output water temperature of 35°C.

NXHM 008 - COOLING

	Load factor	Outdoor temperature (°C)	EER
EER1	100%	35	3.35
EER2	75%	30	4.71
EER3	50%	25	6.65
EER4	25%	20	8.55

NXHM 010 - HEATING

Performance with full load						
Delivery temperature	35°C		45°C		55°C	
Outdoor temperature	Nominal capacity (kW)	COP	Nominal capacity (kW)	COP	Nominal capacity (kW)	COP
-7	8.00	3.05	7.35	2.55	6.85	2.00
2	8.20	4.00	7.85	3.20	8.10	2.56
7	10.00	4.95	10.00	3.75	9.50	3.10
12	9.03	5.77	9.11	4.06	8.50	3.41
15	9.13	6.22	9.22	4.38	8.60	3.67
20	9.58	7.14	9.46	5.08	8.73	4.05
35	8.59	9.01	9.81	6.84	8.63	5.29
Performance with partial load						
Tbival (-7°C)	A	B	C	D		
Outdoor temperature (°C)	-7	2	7	12		
PLR - Climate load factor	0.88	0.54	0.35	0.15		
DC - Output with full load	8.00	8.20	10.00	9.03		
COP with full load	3.05	4.00	4.95	5.77		
COP with partial load	3.05	5.01	7.08	8.58		
CR - Load factor	1.00	0.60	0.32	0.15		
f COP - Corrective factor	1.00	1.25	1.43	1.49		

NOTE: the performance values with a partial load refer to an output water temperature of 35°C.

NXHM 010 - COOLING

	Load factor	Outdoor temperature (°C)	EER
EER1	100%	35	3.25
EER2	75%	30	4.47
EER3	50%	25	7.02
EER4	25%	20	9.54

HEAT PUMPS

Air-water heat pumps

NXHM 012 – HEATING

Performance with full load						
Delivery temperature	35°C		45°C		55°C	
Outdoor temperature	Nominal capacity (kW)	COP	Nominal capacity (kW)	COP	Nominal capacity (kW)	COP
-7	10.00	3.00	10.20	2.40	9.80	2.05
2	9.20	3.90	10.60	3.00	11.30	2.50
7	12.10	4.95	12.30	3.70	11.90	3.05
12	10.98	5.75	11.10	4.26	9.53	3.17
15	11.00	5.97	11.20	4.52	9.12	3.20
20	10.80	7.18	11.20	5.16	9.00	3.61
35	11.50	8.78	11.50	6.17	10.00	4.86
Performance with partial load						
Tbival (-7°C)	A	B	C	D		
Outdoor temperature (°C)	-7	2	7	12		
PLR – Climate load factor	0.88	0.54	0.35	0.15		
DC – Output with full load	10.00	9.20	12.10	10.98		
COP with full load	3.00	3.90	4.95	5.75		
COP with partial load	3.00	4.65	6.62	8.47		
CR – Load factor	1.00	0.67	0.33	0.16		
f COP – Corrective factor	1.00	1.19	1.34	1.47		

NOTE: the performance values with a partial load refer to an output water temperature of 35°C.

NXHM 012 – COOLING

	Load factor	Outdoor temperature (°C)	EER
EER1	100%	35	2.75
EER2	75%	30	3.93
EER3	50%	25	5.73
EER4	25%	20	6.75

NXHM 014 – HEATING

Performance with full load						
Delivery temperature	35°C		45°C		55°C	
Outdoor temperature	Nominal capacity (kW)	COP	Nominal capacity (kW)	COP	Nominal capacity (kW)	COP
-7	12.00	2.85	11.80	2.35	11.00	2.05
2	11.00	3.60	11.50	2.85	12.40	2.45
7	14.50	4.60	14.10	3.60	13.80	2.95
12	11.51	5.46	11.69	4.12	10.28	3.32
15	11.60	5.67	11.90	4.25	9.84	3.41
20	11.10	6.27	11.50	4.87	9.53	3.74
35	11.80	8.63	12.00	6.10	10.10	4.93
Performance with partial load						
Tbival (-7°C)	A	B	C	D		
Outdoor temperature (°C)	-7	2	7	12		
PLR – Climate load factor	0.88	0.54	0.35	0.15		
DC – Output with full load	12.00	11.00	14.50	11.51		
COP with full load	2.85	3.60	4.60	5.46		
COP with partial load	2.85	4.52	6.68	8.52		
CR – Load factor	1.00	0.67	0.33	0.18		
f COP – Corrective factor	1.00	1.26	1.45	1.56		

NOTE: the performance values with a partial load refer to an output water temperature of 35°C.

NXHM 014 – COOLING

	Load factor	Outdoor temperature (°C)	EER
EER1	100%	35	2.50
EER2	75%	30	3.85
EER3	50%	25	5.80
EER4	25%	20	6.74

NXHM 016 – HEATING

Performance with full load						
Delivery temperature	35°C		45°C		55°C	
Outdoor temperature	Nominal capacity (kW)	COP	Nominal capacity (kW)	COP	Nominal capacity (kW)	COP
-7	13.10	2.70	12.80	2.25	12.50	2.00
2	13.00	3.45	12.70	2.85	13.30	2.40
7	15.90	4.50	16.00	3.50	16.00	2.85
12	14.03	5.58	13.76	4.22	12.69	3.44
15	14.50	5.97	14.20	4.46	13.20	3.61
20	12.70	6.88	12.20	4.71	11.20	3.68
35	12.80	9.06	12.50	6.02	10.40	4.57

Performance with partial load				
Tbival (-7°C)	A	B	C	D
Outdoor temperature (°C)	-7	2	7	12
PLR - Climate load factor	0.88	0.54	0.35	0.15
DC - Output with full load	13.10	13.00	15.90	14.03
COP with full load	2.70	3.45	4.50	5.58
COP with partial load	2.70	4.41	6.56	8.51
CR - Load factor	1.00	0.62	0.33	0.16
f COP - Corrective factor	1.00	1.28	1.46	1.53

NOTE: the performance values with a partial load refer to an output water temperature of 35°C.

NXHM 016 – COOLING

	Load factor	Outdoor temperature (°C)	EER
EER1	100%	35	2.50
EER2	75%	30	3.63
EER3	50%	25	5.27
EER4	25%	20	7.29

NXHM 012T – HEATING

Performance with full load						
Delivery temperature	35°C		45°C		55°C	
Outdoor temperature	Nominal capacity (kW)	COP	Nominal capacity (kW)	COP	Nominal capacity (kW)	COP
-7	10.00	3.00	10.20	2.40	9.80	2.05
2	9.20	3.90	10.60	3.00	11.30	2.50
7	12.10	4.95	12.30	3.70	11.90	3.05
12	10.98	5.75	11.10	4.26	9.53	3.17
15	11.00	5.97	11.20	4.52	9.12	3.20
20	10.80	7.18	11.20	5.16	9.00	3.61
35	11.50	8.78	11.50	6.17	10.00	4.86

Performance with partial load				
Tbival (-7°C)	A	B	C	D
Outdoor temperature (°C)	-7	2	7	12
PLR - Climate load factor	0.88	0.54	0.35	0.15
DC - Output with full load	10.00	9.20	12.10	10.98
COP with full load	3.00	3.90	4.95	5.75
COP with partial load	3.00	4.65	6.62	8.47
CR - Load factor	1.00	0.67	0.33	0.16
f COP - Corrective factor	1.00	1.19	1.34	1.47

NOTE: the performance values with a partial load refer to an output water temperature of 35°C.

NXHM 012T – COOLING

	Load factor	Outdoor temperature (°C)	EER
EER1	100%	35	2.75
EER2	75%	30	3.93
EER3	50%	25	5.73
EER4	25%	20	6.75

HEAT PUMPS

Air-water heat pumps

NXHM 014T – HEATING

Performance with full load						
Delivery temperature	35°C		45°C		55°C	
Outdoor temperature	Nominal capacity (kW)	COP	Nominal capacity (kW)	COP	Nominal capacity (kW)	COP
-7	12.00	2.85	11.80	2.35	11.00	2.05
2	11.00	3.60	11.50	2.85	12.40	2.45
7	14.50	4.60	14.10	3.60	13.80	2.95
12	11.51	5.46	11.69	4.12	10.28	3.32
15	11.60	5.67	11.90	4.25	9.84	3.41
20	11.10	6.27	11.50	4.87	9.53	3.74
35	11.80	8.63	12.00	6.10	10.10	4.93

Performance with partial load				
Tbival (-7°C)	A	B	C	D
Outdoor temperature (°C)	-7	2	7	12
PLR – Climate load factor	0.88	0.54	0.35	0.15
DC – Output with full load	12.00	11.00	14.50	11.51
COP with full load	2.85	3.60	4.60	5.46
COP with partial load	2.85	4.52	6.68	8.52
CR – Load factor	1.00	0.67	0.33	0.18
f COP – Corrective factor	1.00	1.26	1.45	1.56

NOTE: the performance values with a partial load refer to an output water temperature of 35°C.

NXHM 014T – COOLING

	Load factor	Outdoor temperature (°C)	EER
EER1	100%	35	2.50
EER2	75%	30	3.85
EER3	50%	25	5.80
EER4	25%	20	6.74

NXHM 016T – HEATING

Performance with full load						
Delivery temperature	35°C		45°C		55°C	
Outdoor temperature	Nominal capacity (kW)	COP	Nominal capacity (kW)	COP	Nominal capacity (kW)	COP
-7	13.10	2.70	12.80	2.25	12.50	2.00
2	13.00	3.45	12.70	2.85	13.30	2.40
7	15.90	4.50	16.00	3.50	16.00	2.85
12	14.03	5.58	13.76	4.22	12.69	3.44
15	14.50	5.97	14.20	4.46	13.20	3.61
20	12.70	6.88	12.20	4.71	11.20	3.68
35	12.80	9.06	12.50	6.02	10.40	4.57

Performance with partial load				
Tbival (-7°C)	A	B	C	D
Outdoor temperature (°C)	-7	2	7	12
PLR – Climate load factor	0.88	0.54	0.35	0.15
DC – Output with full load	13.10	13.00	15.90	14.03
COP with full load	2.70	3.45	4.50	5.58
COP with partial load	2.70	4.41	6.56	8.51
CR – Load factor	1.00	0.62	0.33	0.16
f COP – Corrective factor	1.00	1.28	1.46	1.53

NOTE: the performance values with a partial load refer to an output water temperature of 35°C.

NXHM 016T – COOLING

	Load factor	Outdoor temperature (°C)	EER
EER1	100%	35	2.50
EER2	75%	30	3.63
EER3	50%	25	5.27
EER4	25%	20	7.29

OPERATING LIMITS NXHM

COOLING MODE

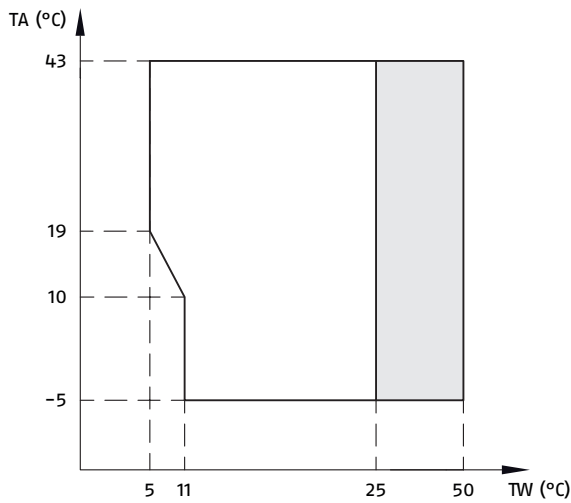

TA Outside air temperature.
TW Water delivery temperature.

Operating range with heat pump, with possible limits and protection.

HEATING MODE

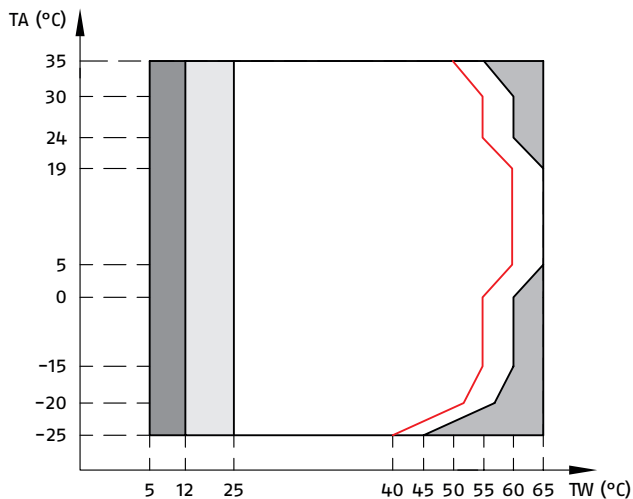

TA Outside air temperature.
TW Water delivery temperature.

Operating range with heat pump, with possible limits and protection.
The heat pump switches off and only the external heat source is active.
If the external heat source setting is enabled, that is the only heat source active.
If the external heat source setting is disabled, only the heat pump is active. Cases of limits and protection may arise while the heat pump is operating.
Maximum temperature line for the inlet water with heat pump operation.

DHW MODE

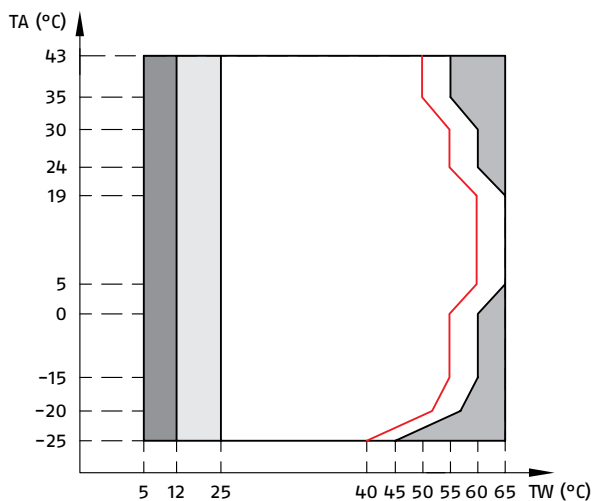

TA Outside air temperature.
TW Water delivery temperature.

Operating range with heat pump, with possible limits and protection.
The heat pump switches off and only the external heat source is active.
If the external heat source setting is enabled, that is the only heat source active.
If the external heat source setting is disabled, only the heat pump is active. Cases of limits and protection may arise while the heat pump is operating.
Maximum temperature line for the inlet water with heat pump operation.

HEAT PUMPS

Air-water heat pumps

OVERALL DIMENSIONS

NXHM 004-006

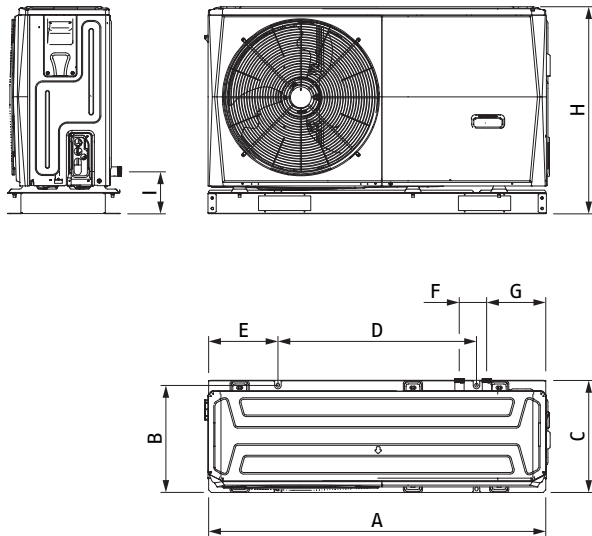

NXHM 008-016

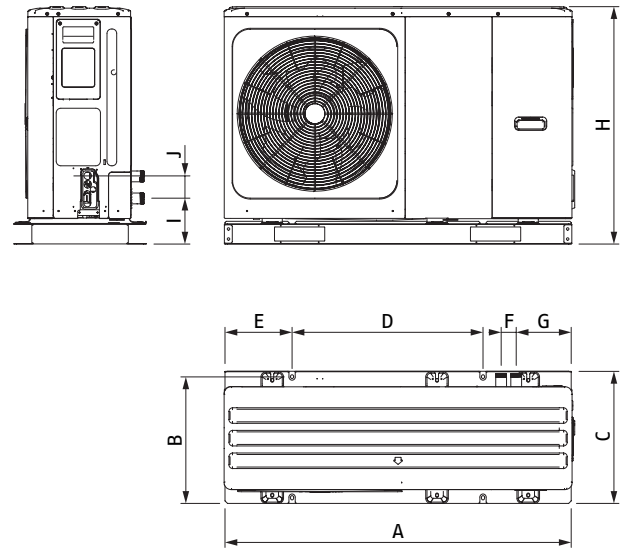

	A	B	C	D	E	F	G	H	I	J
	mm	mm	mm	mm	mm	mm	mm	mm	mm	mm
NXHM 004-006	1295	365	429	760	265	105	225	792	161	-
NXHM 008-016	1385	438	526	760	270	60	221	945	182	81

PLACE OF INSTALLATION

The unit is equipped with flammable refrigerant and must be installed outdoors in a well-ventilated place. Make sure that appropriate measures are taken to prevent the unit from being used as a shelter by small animals.

Choose an installation site that meets the following conditions:

- Well-ventilated.
- In an area which will not disturb any neighbours.
- On a level surface able to support the weight of the unit as well as any vibrations.
- In an area allowing maintenance to be carried out.

When installing the unit in a location exposed to strong wind, pay special attention to the following.

Strong winds of 5 m/sec or more blowing against the air outlet of the unit may cause a short circuit (exhaust air intake), which could have the following consequences:

- Deterioration of operational capacity.
- Frequent frost acceleration when operating in heating mode.
- Interruption of operation due to increased high pressure.
- When a strong wind blows continuously on the front of the unit, the fan can start to rotate quickly causing it to break.

When using the unit in cold climates, observe the instructions provided below:

- Never install the unit in a place where the intake side can be directly exposed to the wind.
- In areas with heavy snowfall, it is extremely important to choose an installation site where snow will not affect the device. If it is possible for snow to fall from the side, make sure that the heat exchanger coil is not affected by snow (if necessary, build a canopy).
- Install the unit high enough to prevent it from being buried in snow.

In normal conditions

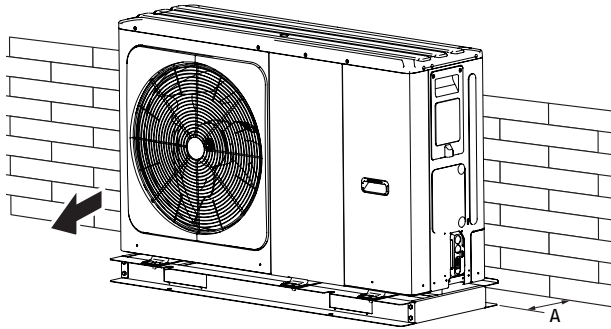

	A
	mm
NXHM 004-006	≥300
NXHM 008-016	≥300

In conditions of high wind

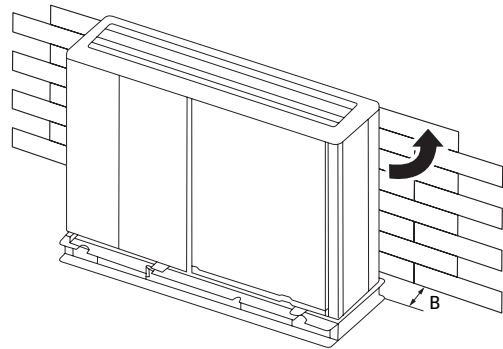

	B
	mm
NXHM 004-006	≥1000
NXHM 008-016	≥1500

In a cold climate

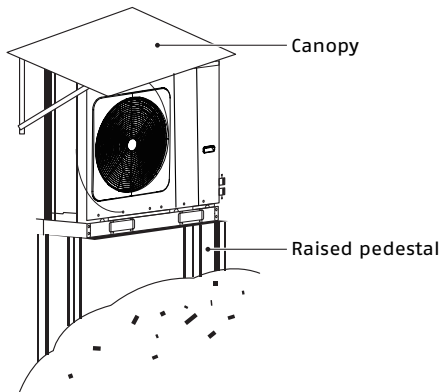

In the case of stacked installation

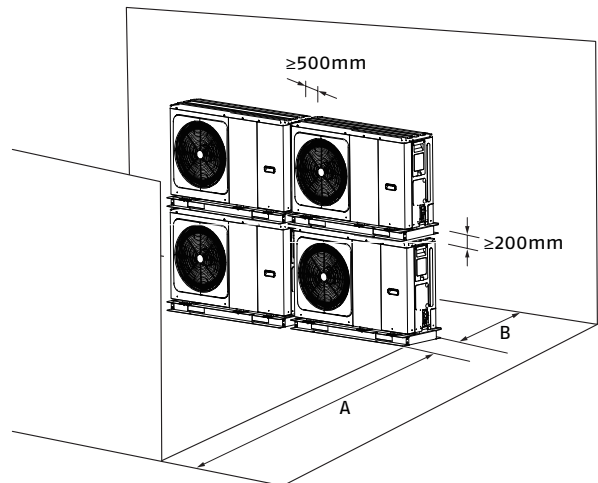

	A	B
	mm	mm
NXHM 004-006	≥1000	≥300
NXHM 008-016	≥1500	≥300

A: If there is an obstacle to the front. - B: If there is an obstacle to the rear.

In the case of installation in several rows

	A	B1	B2	C
	mm	mm	mm	mm
NXHM 004-006	≥2500	≥1000	≥300	≥600
NXHM 008-016	≥3000	≥1500	≥300	≥600

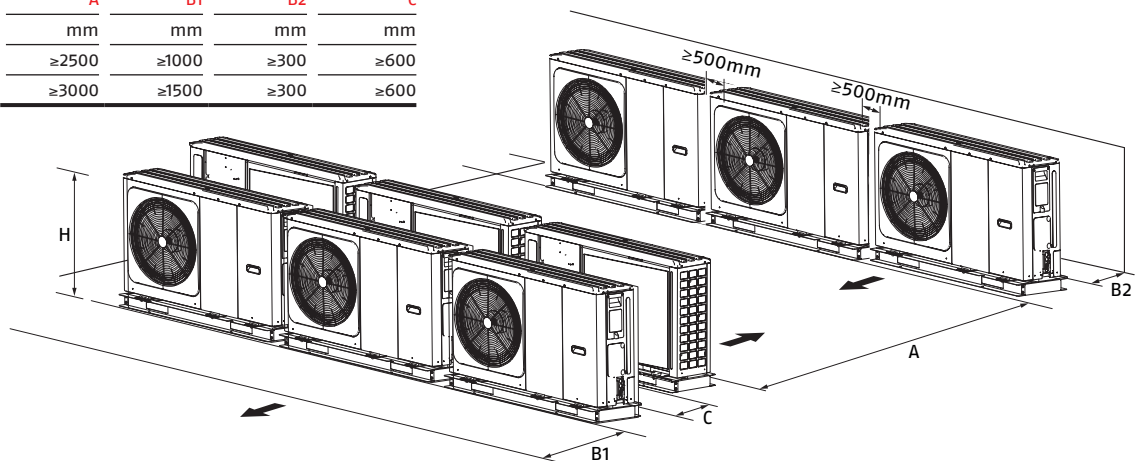

HEAT PUMPS

Air-water heat pumps

STRUCTURE

NXHM 004-006

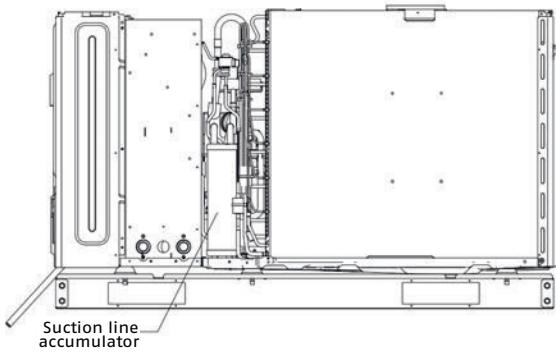
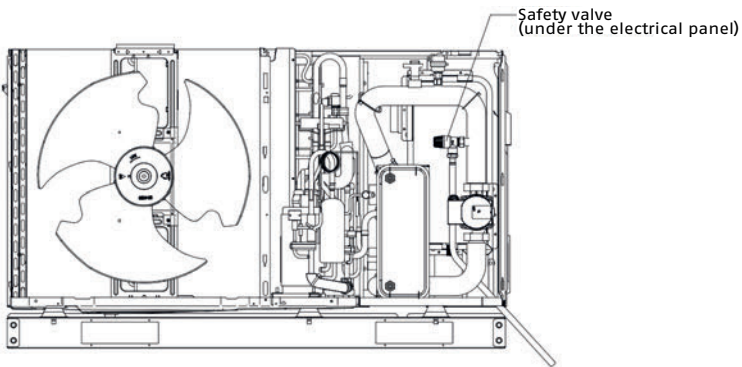
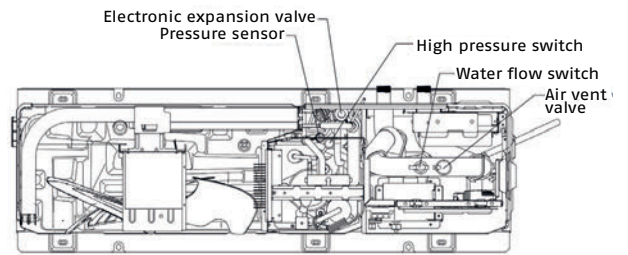
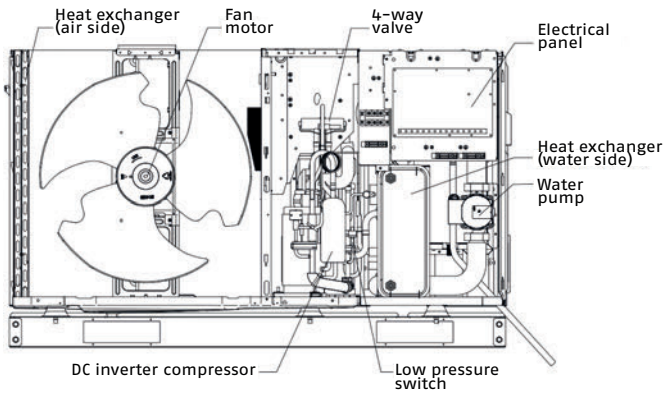

NXHM 008-010

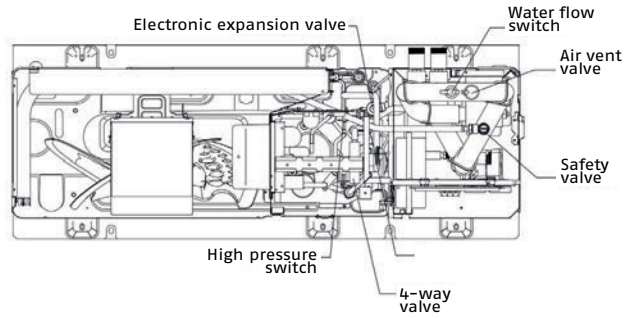
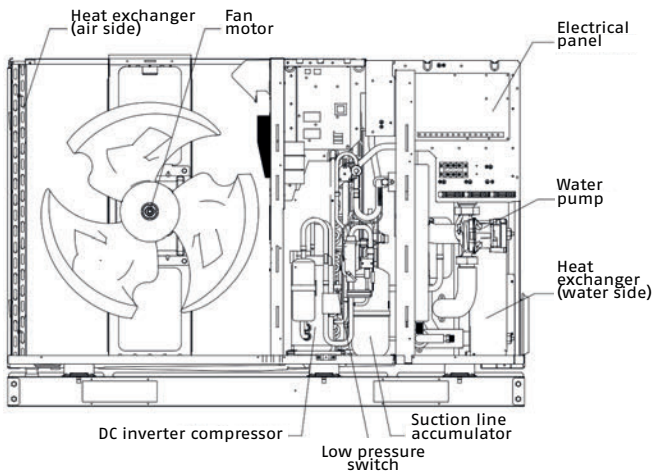

NXHM 012-016

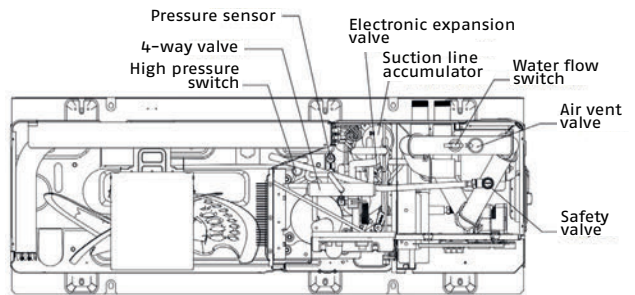
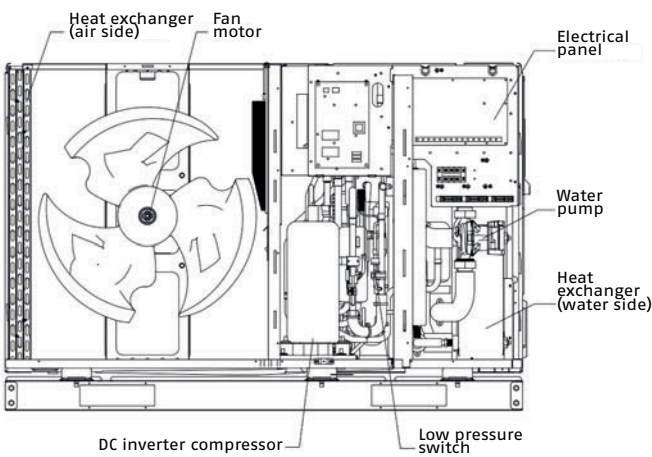

NXHM 012T-016T

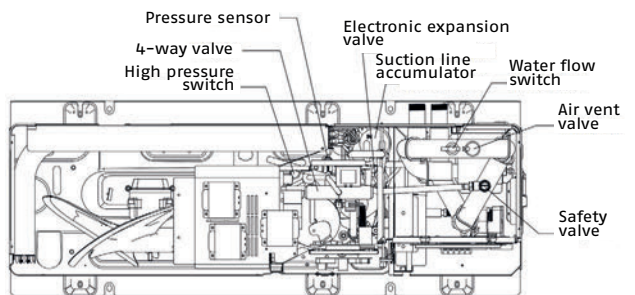
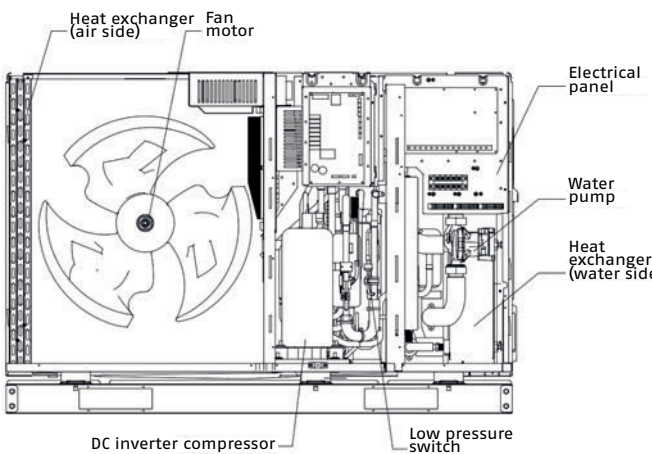

HEAT PUMPS

Air-water heat pumps

PLUMBING CONNECTIONS

NXHM 004-006

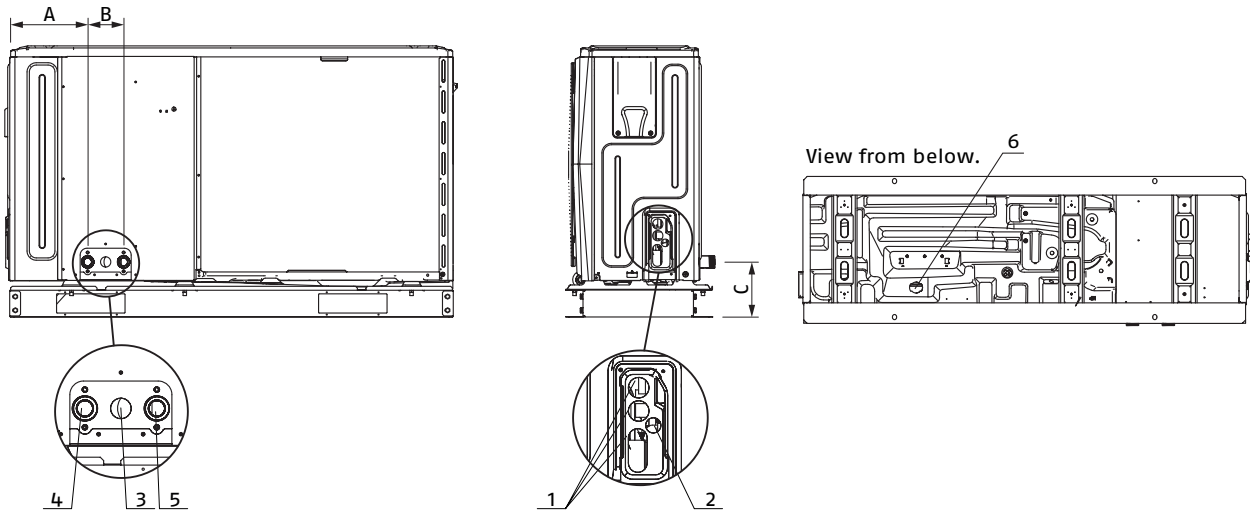

NXHM 008-016 - 012T-016T

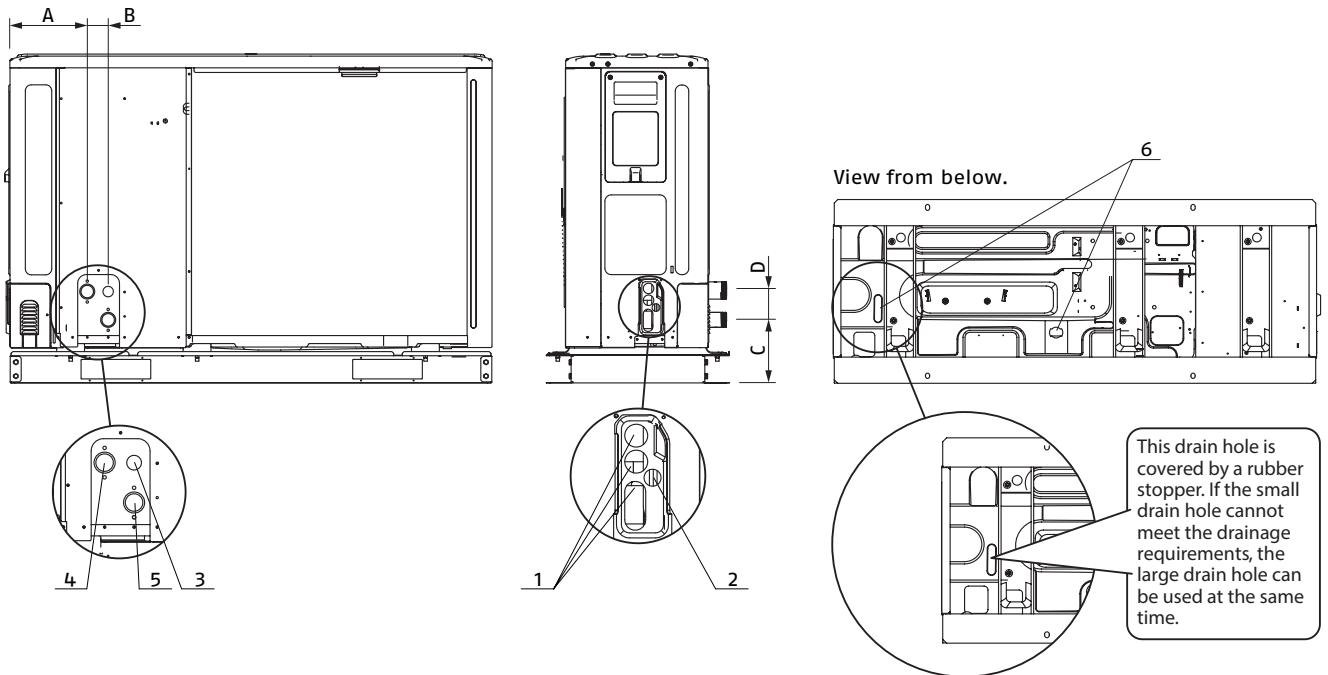

	Model	UM	NXHM 004-006	NXHM 008-016 - 012T-016T
1	Hole for the HV wire	∅ mm	25	25
2	Hole for the LV wire	∅ mm	15	15
3	Hole for safety valve drain pipe	∅ mm	10	10
4	Water outlet	∅	1"	1 1/4"
5	Water inlet	∅	1"	1 1/4"
6	Condensate outlet hose fitting (included)	∅ mm	28	28
A		mm	225	221
B		mm	105	60
C		mm	161	182
D		mm	-	81

DIAGRAM OF FLOW RATE – HEAD – LOAD LOSS

NXHM is fitted with a variable speed circulation pump.
When sizing the system, bear in mind the residual discharge head shown in the following charts.

Model	UM	NXHM									
		004	006	008	010	012	014	016	012T	014T	016T
Available pump head (A7; W35) (1)	kPa	85	84	78	69	59	47	39	59	47	39

(1) Outdoor air temperature 7°C BS, 6°C BU; water inlet/outlet 30/35°C.

NXHM 004-010

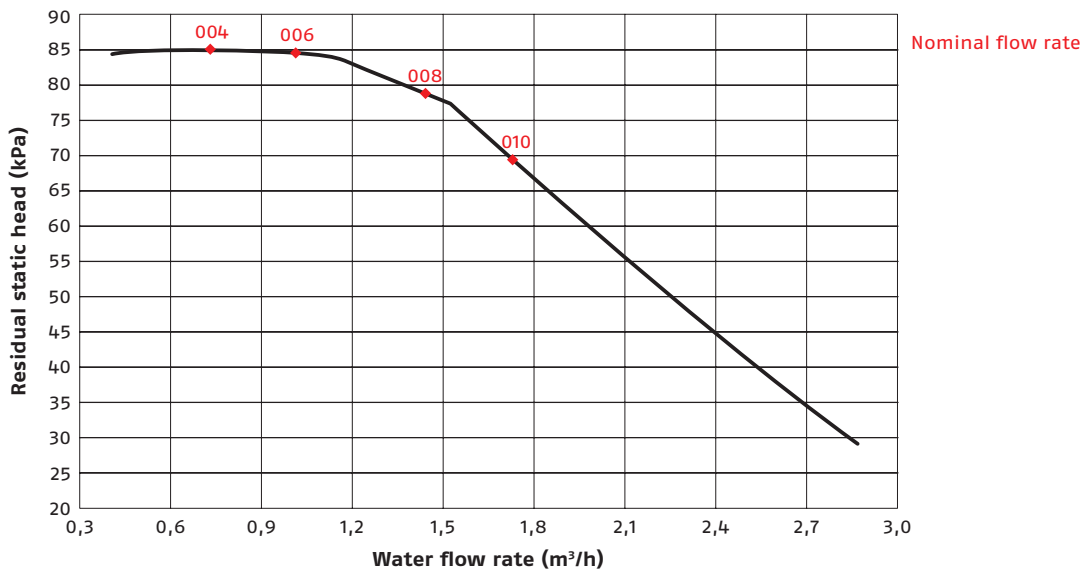

NXHM 012-016 - 012T-016T

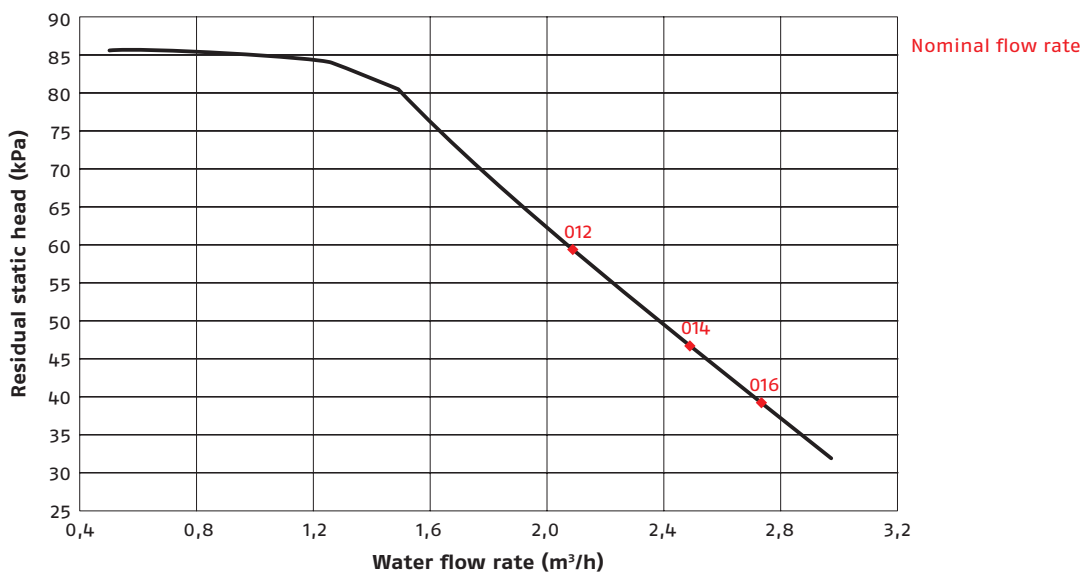

HEAT PUMPS

Air-water heat pumps

WATER IN THE HEATING SYSTEMS

CHEMICAL-PHYSICAL CHARACTERISTICS

The chemical-physical characteristics of the water must comply with European standard EN 14868 and the tables below:

System water reference values		
pH	-	7 - 8
Electrical conductivity	µS/cm	10 - 600
Chlorine ions	mg/l	< 10
Sulphuric acid ions	mg/l	< 30
Total iron	mg/l	< 5
Alkalinity M	mg/l	< 100
Total hardness	mmol/l	1 - 2.5
Sulphur ions	-	none
Ammonia ions	-	none
Silicon ions	mg/l	< 1

Well or groundwater not coming from the aqueduct should always be carefully analysed and if necessary conditioned with appropriate treatment systems.

If the initial water hardness exceeds the value indicated in the table, a water softening system must be used.

Excessive water softening (total hardness < 1.5 mmol/l) could lead to corrosion on contact with metal elements (pipes or boiler parts). The conductivity value must also be kept within 600 µS/cm.

Check the chloride concentration at the outlet after regeneration of the resins.

It is strictly prohibited to introduce acids into the washing circuit.

It is strictly prohibited to constantly or frequently top up the system, as this can damage the heat exchanger of the appliance.

SYSTEM WATER CONTENT AND FLOW RATE

Heat pumps require systems that guarantee a constant fluid flow rate to the device, within minimum and maximum values and with sufficient volumes to avoid any imbalance in the cooling circuits and ensure the correct degree of comfort.

SYSTEM WATER CONTENT

A minimum volume of water in the system's primary circuit must be guaranteed for the appliance to operate correctly.

The minimum volume is necessary to prevent the risk of ice formation during defrosting operations or continuous modulation of the compressor frequency.

It also provides the following advantages:

- less appliance wear;
- increase in system efficiency;
- improved stability and temperature precision.

The water flow rate must be kept constant during operation, and must respect the limits shown in the table:

Model	UM	NXHM										
		004	006	008	010	012	014	016	012T	014T	016T	
Minimum system water content (1) (2)	l	25	25	25	25	40	40	40	40	40	40	40
Minimum water flow rate	m ³ /h	0.40	0.40	0.40	0.40	0.70	0.70	0.70	0.70	0.70	0.70	0.70
Maximum water flow rate	m ³ /h	0.90	1.25	1.65	2.10	2.50	2.75	3.00	2.50	2.75	3.00	3.00

(1) Excluding the volume of water inside the unit.

(2) In the case of cascade installation, the minimum volume should be $\geq 40 \text{ l} \cdot n$ where n is the number of connected units.

ELECTRICAL WIRING

SAFETY DEVICE REQUISITES:

- Select the cable diameters (minimum value) individually for each unit on the basis of tables 1 and 2, where the nominal current in table 1 means MCA in table 2. If the MCA is higher than 63A, the wire diameters must be selected in accordance with the national wiring regulations.
- The maximum permitted variation between the phases in the voltage field is 2%.
- Select the circuit breaker that separates the contacts by at least 3mm on all the poles and allows for complete disconnection, where the MFA is used to select the current circuit breakers and the residual current circuit breakers.

SIZING THE CABLES

For the sizing of the electricity supply cable and the safety appliances, refer to the tables below:

Table 1

Nominal current of the appliance: (A)	Nominal cross section area (mm ²)	
	Flexible cables	Fixed wiring cable
≤3	0.5 and 0.75	1 and 2.5
>3 and ≤6	0.75 and 1	1 and 2.5
>6 and ≤10	1 and 1.5	1 and 2.5
>10 and ≤16	1.5 and 2.5	1.5 and 4
>16 and ≤25	2.5 and 4	2.5 and 6
>25 and ≤32	4 and 6	4 and 10
>32 and ≤50	6 and 10	6 and 16
>50 and ≤63	10 and 16	10 and 25

Table 2 Standard 4-16 kW single-phase and standard 12-16 kW three-phase

System	Outdoor unit				Supply current			Compressor		OFM	
	Voltage (V)	Hz	Min. (V)	Max. (V)	MCA (A)	TOCA (A)	MFA (A)	MSC (A)	RLA (A)	kW	FLA (A)
4 kW	220-240	50	198	264	12	18	25	-	11.50	0.10	0.50
6 kW	220-240	50	198	264	14	18	25	-	13.50	0.10	0.50
8 kW	220-240	50	198	264	16	19	25	-	14.50	0.17	1.50
10 kW	220-240	50	198	264	17	19	25	-	15.50	0.17	1.50
12 kW	220-240	50	198	264	25	30	35	-	23.50	0.17	1.50
14 kW	220-240	50	198	264	26	30	35	-	24.50	0.17	1.50
16 kW	220-240	50	198	264	27	30	35	-	25.50	0.17	1.50
12 kW three-phase	380-415	50	342	456	10	14	16	-	9.15	0.17	1.50
14 kW three-phase	380-415	50	342	456	11	14	16	-	10.15	0.17	1.50
16 kW three-phase	380-415	50	342	456	12	14	16	-	11.15	0.17	1.50

MCA: Maximum circuit ampacity (A)

TOCA: Total overcurrent amps (A)

MFA: Maximum fuse amps (A)

MSC: Maximum starting current (A)

RLA: In test conditions with nominal cooling or heating, the compressor input amps where MAX. Hz can work with the nominal load amps (A)

kW: Nominal motor output

FLA: Amperage with full load (A)

HEAT PUMPS

Air-water heat pumps

REMOVING THE ELECTRICAL PANEL COVER

Standard 4-16 kW single-phase and standard 12-16 kW three-phase

System	4 kW	6 kW	8 kW	10 kW	12 kW	14 kW	16 kW	12 kW three-phase	14 kW three-phase	16 kW three-phase
Maximum overcurrent protection (MOP) (A)	18	18	19	19	30	30	30	14	14	14
Cable dimensions (mm ²)	4.0	4.0	4.0	4.0	6.0	6.0	6.0	2.5	2.5	2.5

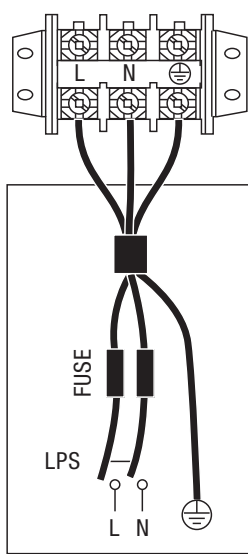

single-phase UNIT
POWER SUPPLY

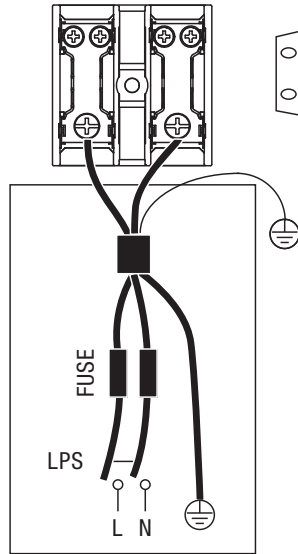

single-phase UNIT
POWER SUPPLY

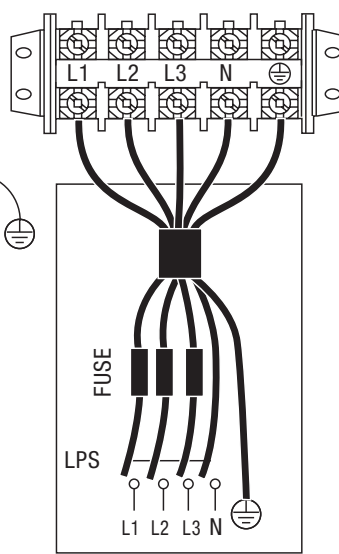

three-phase UNIT
POWER SUPPLY

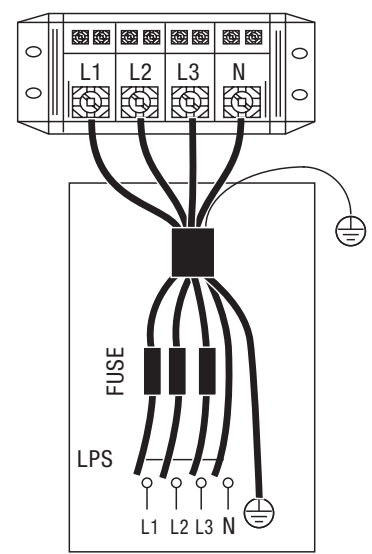

three-phase UNIT
POWER SUPPLY

CONNECTIONS FOR OTHER COMPONENTS

For the electrical wiring details, refer to the product INSTALLER manual.

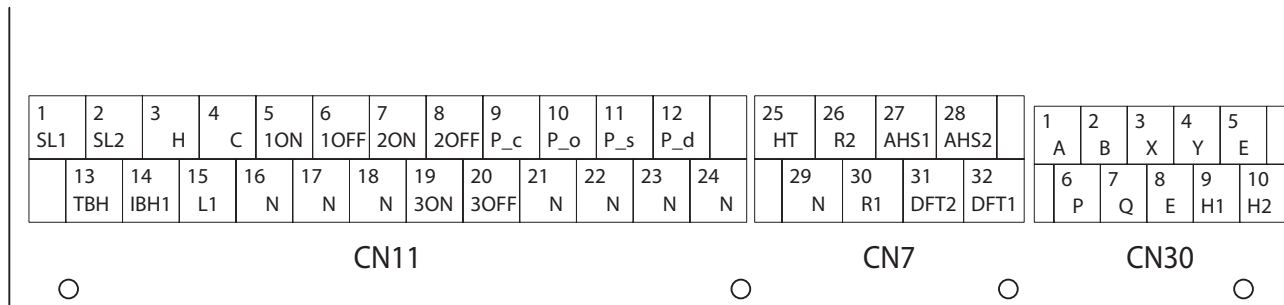

	CODE	PRINT	CONNECTION TO
CN11	1	1 SL1 2 SL2	Solar energy input signal
	2	3 H 4 C	Room thermostat input (high voltage)
	3	5 1ON 6 1OFF 16 N	SV1 (3-way valve)
	4	7 2ON 8 2OFF 17 N	SV2 (3-way valve)
	5	9 P_c 21 N	Pump c (zone 2 pump)
	6	10 P_o 22 N	External circulation pump (zone 1 pump)
	7	11 PN_s 23 N	Solar energy pump
	8	12 PN_d 24 N	DHW tube pump
	9	13 TBH 16 N	Tank booster heater
	10	14 IBH1 17 N 18 N	Backup heater
	11	19 3ON 20 3OFF	SV3 (3-way valve)

	CODE	PRINT	CONNECTION TO
CN7	1	26 R2 30 R1	Compressor operation
		31 DFT2 32 DFT1	Defrosting operation
	2	25 HT 29 N	Anti-freeze heating element (external)
	3	27 AHS1 28 AHS2	Additional heating source

	CODE	PRINT	CONNECTION TO
CN30	1	1 A 2 B 3 X 4 Y	Wired control panel
	2	5 E 6 P 7 Q	Outdoor unit
	3	8 E 9 H1 10 H2	Internal parallel machine

The port supplies the load with the control signal.

Two types of control signal port:

Type 1: Input of the clean contact type.

Type 2: The port supplies the signal with a 220V voltage. If the load current is <0.2 A, the load can be connected directly to the port. If the load current is >=0.2A, the AC contactor must be connected for the load.

HEAT PUMPS

Air-water heat pumps

CONTROL PANEL

The control panel is the interface for the installer and the user to carry out all operations to set the operating parameters and display the status of the components in the device.

Depending on the temperatures detected by the probes in the appliance and any probes installed in the domestic hot water tank, in the room and externally, the electronics modulate appliance operation, and the operating condition can be shown in the display.

Use the panel to set the required temperature for the system and for domestic hot water.

NXHM can be controlled via:

- Control panel
- REC10MH control panel
- External consents
- Modbus RTU

Control panel

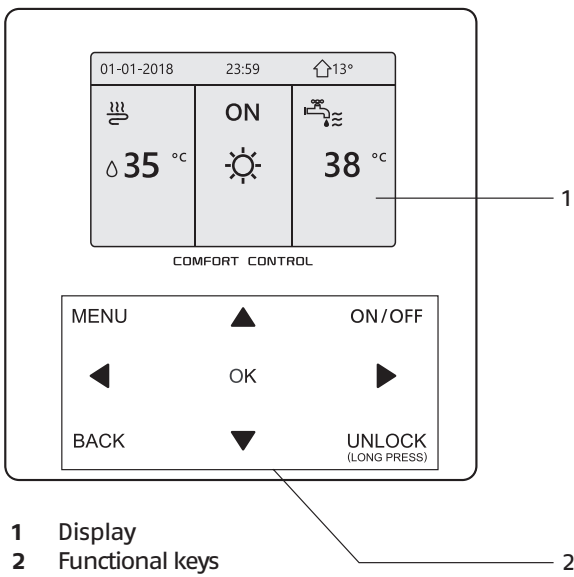

Key	Description
MENU	Go to the menu structure (on the home page)
◀▶▲▼	Move the cursor on the display Move within the menu structure Adjust the settings
ON/OFF	Activate/ deactivate room heating /cooling operation or DHW mode Activate or deactivate functions in the menu structure
BACK	Go back to the next higher level
UNLOCK	Press and hold to unlock/lock the controller Unlock/lock certain functions such as 'DHW temperature control'.
OK	Go to the next step when setting a programming in the menu structure; confirm a selection to access a submenu in the menu structure

REC10MH user interface

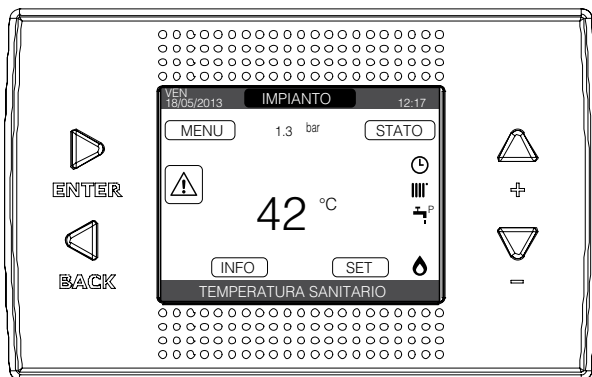



The user interface of the unit, also called "REC10MH interface", is installed at a distance.

It's an extremely simple, user-friendly interface designed to enable the user to set the system operating temperatures for heating and air conditioning and the inertial DHW tank.

Refer to the specific manual for all the details about using this control.

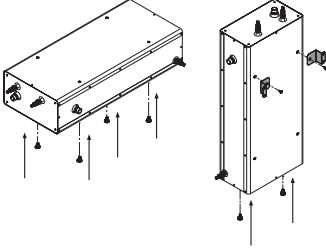
ACCESSORIES

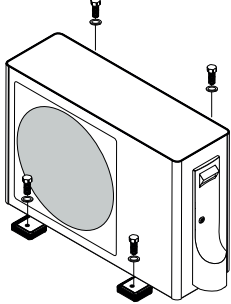
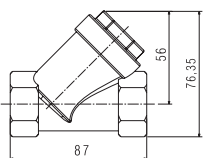
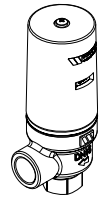
	Description	004	006	008	010	012	014	016
NXHM HEAT PUMP ACCESSORIES								
	<p>50-litre inertial storage tank: insulated inertial storage tank with painted casing, for outdoor/ indoor installation. Its particular shape allows it to be positioned both horizontally and vertically (using wall brackets).</p> <p>Measurements: 1080 x 470 x 250 mm (not including vents, brackets and support feet) Water fittings: G 1" M.</p>	•	•	•	•	•	•	•
	<p>120-litre 7000 ACI Plus inertial storage tank. Insulated hot/cold inertial storage tank for indoor installation. Comes with brackets for installation on the wall if necessary.</p> <p>Measurements: diam. 500 x H. 1095 mm (not including vents, brackets and support feet) Water fittings: G 1 1/4" F.</p>	•	•	•	•	•	•	•
	<p>Heat pump vibration damper kit.</p>	•	•	•	•	•	•	•
	<p>1" Y water filter.</p>	•	•	•	•	•	•	•
	<p>Adjustable bypass valve: adjustable overpressure valve to allow the recirculation/bypass of a certain (adjustable) flow rate of heat transfer fluid to prevent the differential heat pump flow switches and pressure switches from being triggered.</p> <p>Valve characteristics:</p> <ul style="list-style-type: none"> - a brass body and an ABS cap - PN10 - 1/2" FF connections - differential opening pressure 0.05 - 0.07 bar - suitable for bypass flow rates up to 1760 l/h. 	•	•	•				

HEAT PUMPS

Air-water heat pumps

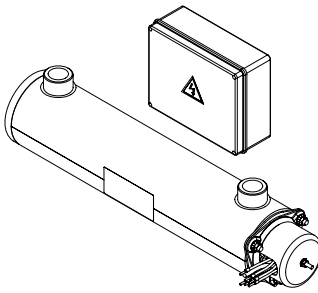
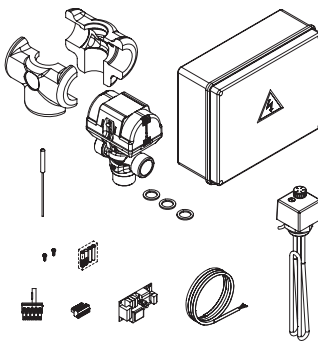
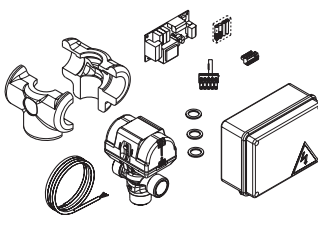
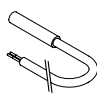
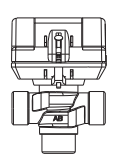
	Description	004	006	008	010	012	014	016
	<p>1PH 3PH supplementary electric heater from 2kW to 6kW: the kit is positioned on the heat pump outlet, and can provide thermal support (2.4 or 6 kW for the single-phase connection, or 6kW only for the three-phase connection) in full-electric systems.</p> <p>The kit contains:</p> <ul style="list-style-type: none"> - electric heater - electric box complete with electronic control board - connectors and wiring. 	•	•	•	•	•	•	•
	<p>Single-phase DHW storage cylinder electric heater 2.2kW: the heater is installed directly on the storage cylinder to guarantee DHW production even in the most extreme conditions. The REC10MH remote panel is compulsory, for correct programming.</p> <p>The kit contains:</p> <ul style="list-style-type: none"> - electric heater, 3-way valve and storage cylinder probe - electric box complete with electronic control board - connectors and wiring. 	•	•	•	•	•	•	•
	<p>DHW diverting valve with storage cylinder probe: this kit provides a diverting valve for filling a DHW storage cylinder, exploiting the circulator of the main direct zone.</p> <p>It also contains an electric box complete with an electronic control board with the "photovoltaic" function (that can be activated according to the generator pump model used). To be used only in combination with the REC10MH.</p> <p>The kit contains:</p> <ul style="list-style-type: none"> - 3-way diverting valve - couplings and insulation - electric box complete with electronic control board - Storage tank probe - connectors and wiring. 	•	•	•	•	•	•	•
	<p>Storage cylinder/puffer/cascade/mixing zone/solar probe: to be used in applications where the REC10MH panel is not used. Can be used as a cascade temperature probe, a puffer probe, a mixing zone probe or a solar probe.</p>	•	•	•	•	•	•	•
	<p>1" DHW diverting valve with storage cylinder probe. The DN25 1" diverting valve is used to manage the heating of the DHW storage cylinder in combi systems. We recommend that this accessory be positioned as close as possible to the internal heat pump module. The kit includes a storage cylinder probe.</p> <p>To be used in combination with the NXHM control panel (supplied as standard with the unit).</p>	•	•	•	•	•	•	•

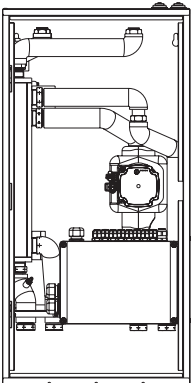
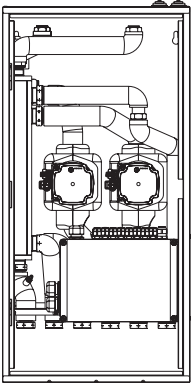
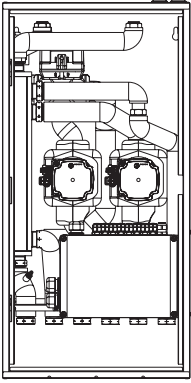
	Description	004	006	008	010	012	014	016
DISTRIBUTION MODULES WITH SEPARATOR								
	<p>BAG3 HYBRID 1D: pre-assembled hydraulic distribution system for 1 direct zone, consisting of a vertical hydraulic flexible spacer, a twin coupling for 2 separate generators (boiler and heat pump), 1 high-head circulator, 1 flow sensor, 1 low temperature limit thermostat, and a pre-wired electronic ModBus board.</p> <p>The kit includes closed cell insulation which is ideal for use in cooling mode as well, to prevent the formation of condensate. The zone can be set with the following operating modes:</p> <ul style="list-style-type: none"> - heating only - cooling only - heating and cooling. <p>This product code relates to the internal components only; Bag3 Hybrid must be completed with the "flush-mounting box".</p>	•	•	•	•	•	•	•
	<p>BAG3 HYBRID 2D: pre-assembled hydraulic distribution system for 2 direct zones, consisting of a vertical hydraulic flexible spacer, a twin coupling for 2 separate generators (boiler and heat pump), 2 high-head circulators, 2 flow sensors, 2 low temperature limit thermostats, and 2 pre-wired electronic ModBus boards.</p> <p>The kit includes closed cell insulation which is ideal for use in cooling mode as well, to prevent the formation of condensate. The zones are all independent of each other, and can be set with the following operating modes:</p> <ul style="list-style-type: none"> - heating only - cooling only - heating and cooling. <p>This product code relates to the internal components only; Bag3 Hybrid must be completed with the "flush-mounting box".</p>	•	•	•	•	•	•	•
	<p>BAG3 HYBRID 1D+1M: pre-assembled hydraulic distribution system for 1 direct zone and 1 mixing zone, consisting of a vertical hydraulic flexible spacer, a twin coupling for 2 separate generators (boiler and heat pump), 2 high-head circulators, 1 motorised mixing pump, 2 flow sensors, 2 low temperature limit thermostats, and 2 pre-wired electronic ModBus boards.</p> <p>The kit includes closed cell insulation which is ideal for use in cooling mode as well, to prevent the formation of condensate. The zones are all independent of each other, and can be set with the following operating modes:</p> <ul style="list-style-type: none"> - heating only - cooling only - heating and cooling. <p>This product code relates to the internal components only; Bag3 Hybrid must be completed with the "flush-mounting box".</p>	•	•	•	•	•	•	•

HEAT PUMPS

Air-water heat pumps

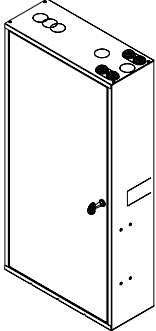
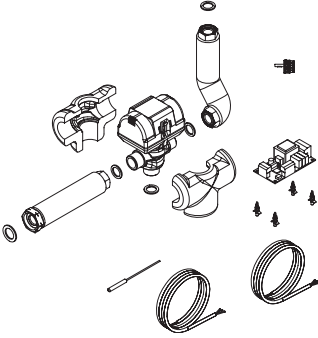
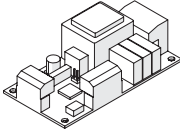
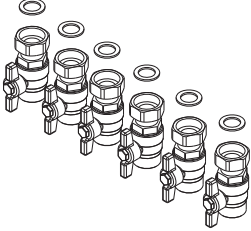
	Description	004	006	008	010	012	014	016
	<p>Flush-mounting box: galvanised sheet metal box (400 x 797 x 160 mm) containing all the brackets needed to sustain the components (hydraulic and electric) of Bag3 Hybrid.</p> <p>The box has a lockable door (the key is supplied as standard), and can be installed in "flush-mounting" or "suspended" mode.</p>	•	•	•	•	•	•	•
Description						1D	2D	1D + 1M
HYBRID DISTRIBUTION MODULE ACCESSORIES								
	<p>Diverting valve for BAG3 Hybrid: this kit provides a diverting valve for filling a DHW storage cylinder directly from the Bag3 Hybrid, exploiting the circulator of the main direct zone. It also contains an electronic control board with the "photovoltaic" function (that can be activated according to the generator pump model used).</p> <p>The kit contains:</p> <ul style="list-style-type: none"> - 3-way diverting valve - couplings and insulation - electronic control board (to be installed in an electric box inside Bag3 Hybrid) - storage cylinder probe - connectors and wiring. 	•	•	•				
	<p>Board for photovoltaic system input: this kit allows the system to receive a signal (clean contact) from the photovoltaic panel, using it to define the operating priorities of the heat sources.</p> <p>The board is supplied complete with wiring (electrical supply and BUS connection), and must be installed in an electric box (not supplied).</p>	•	•	•				
	<p>Taps for BAG3 Hybrid: 6 butterfly taps for shutting off the system side and heat pump side.</p> <p>This kit comes complete with 6 metres of adhesive insulation for avoiding heat loss and the formation of condensate.</p>	•	•	•				

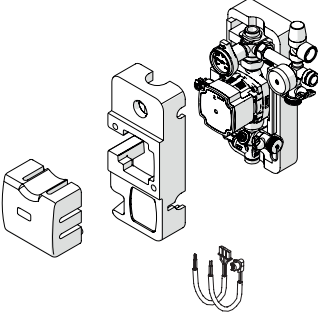
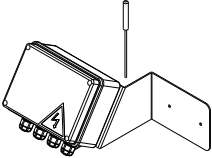
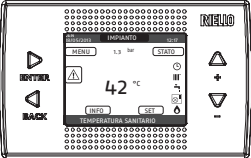
	Description	004	006	008	010	012	014	016
SOLAR THERMAL ACCESSORIES								
	<p>RSS R solar hydraulic unit: this kit is used to fully manage small solar systems. It must be purchased together with the solar interface kit.</p> <p>The kit contains:</p> <ul style="list-style-type: none"> - solar station - circulator cover with logo - connectors and wiring. 	•	•	•	•	•	•	•
	<p>Solar thermal interface board: this kit uses REC10MH system intelligence to manage the solar hydraulic unit (code 20116168).</p> <p>The kit consists of:</p> <ul style="list-style-type: none"> - 1 electronic control board in an electric box - 2 probes (1 solar probe and 1 DHW storage cylinder probe) - 1 support bracket with fixing elements. 	•	•	•	•	•	•	•
CONTROL PANELS								
	<p>REC10MH remote control panel for an additional zone or hybrid system management: complete with a header for wall installation, and a power supply unit (to be installed in an electric box) for monitoring the entire system connected to it - e.g. the generators (settings and alarms, depending on the generator model used) and the temperatures and time bands of the controlled zone. It is a compulsory accessory in full-electric systems.</p> <p>The panel interfaces via ModBus with the boilers and heat pumps, with Bag3 Hybrid, and with the control boards of the direct or mixing zone.</p>	•	•	•	•	•	•	•

HEAT PUMPS

Air-water heat pumps

NXHM 004-016

PRODUCT DESCRIPTION FOR SPECIFICATIONS

Outdoor monobloc air-water heat pump, single-phase and three-phase, with DC-inverter control and MITSUBISHI twin rotary compressor for all sizes to guarantee optimum dynamic balancing and reduce vibration, with continuous modulation from approx. 40% to 120%, designed to work with R32 refrigerant gas.

Given the wide operating range, it's ideal for every type of system, whether hybrid or monovalent. In heating mode in fact, it can supply water at 60°C with an outdoor temperature as low as -15°C, and in cooling mode water at 7°C with an outdoor temperature up to 43°C, and can also produce domestic hot water thanks to storage tanks and fixed coils or heat exchangers for instantaneous DHW production, as it can supply delivery water at 55°C with a temperature of 43°C outside.

Top level performance. Up to A+++ for low temperatures and A++ for medium temperatures in temperate zones, according to EN 14825_2016. All the performance values are certified by HP Keymark, MCS.

Built in accordance with the European eco-design regulations, that define the requisites for the ERP (Energy Related Products) standard in order to improve energy efficiency.

CHARACTERISTICS

- NXHM provides an extremely high level of energy efficiency in both heating and cooling mode, thereby guaranteeing significant energy savings. The large, high-efficiency coils, together with the optimised circuits, ensure results that meet the European tax relief requisites. Efficiency levels in partial load conditions (seasonal energy efficiency) are the highest in this industrial sector.
- Comfort throughout the year: the ground-breaking technology employed for NXHM means boosted comfort levels for users in terms of both water temperature control and quiet operation. The required temperature is reached quickly and kept constant, without any fluctuations. NXHM offers optimised, personalised comfort levels both in winter and in summer.
- NXHM can work in cooling mode even with low outdoor temperatures (from -25°C, and up to 43°C). To ensure the maximum comfort for the user, the units work in heating mode with outdoor temperatures down to -25°C, whereas in summer they can produce hot water up to 50°C for DHW applications, with the outdoor temperature as high as 43°C.
- In the ambient comfort modes (both heating and cooling), weekly programming is a standard feature.
- In the DHW modes, weekly programming and an anti-legionella function – with thermal disinfection – are available as standard.
- A multitude of possible system layouts. Thanks to the sensors available as accessories, the unit can manage – for example – a solar system, one or two zones (one of them mixed) and DHW recirculation.
- The possibility to link up to 6 units in a cascade. In cascade configurations, the master unit can be dedicated to DHW production.
- The possibility to connect the unit with BMS systems using the Modbus protocol.
- USB port available for updating the technical board software.
- A clean input is available, dedicated to smart grid functions.
- Operation guaranteed with at least 40lt of water in the system.

UNIT COMPONENTS

- **STRUCTURE:**
Cabinet made of sheet steel painted with neutral-coloured powders (RAL 7035) to enhance resistance to corrosion caused by atmospheric agents. All the panels are removable.
- **COMPRESSOR:**
The compressor has a double protective sound insulation shield to further reduce the noise levels.
Advanced technology ensuring optimum energy efficiency and characterised by high output levels in peak conditions and optimised efficiency at low and medium compressor speeds.
The NXHM heat pump uses DC inverter technology that combines two electronic adjustment logics, pulse amplitude modulation (PAM) and pulse width modulation (PWM), to guarantee optimised compressor operation in all working conditions, minimise temperature fluctuation and ensure perfect comfort adjustment whilst at the same time considerably reducing energy consumption.
 - PAM: the modulation of the direct current pulse amplitude commands the compressor to work in maximum load conditions (start-up and peak load) so as to increase the voltage in the case of a fixed frequency. The compressor works at high speed to quickly reach the required temperature.
 - PWM: the modulation of the direct current pulse width commands the compressor to work in partial load conditions, adapting the frequency in the case of a fixed voltage. The compressor speed is precisely adjusted and the system offers a high comfort level (no temperature fluctuations) in working conditions of outstanding efficiency.The compressor frequency increases constantly until it reaches the maximum level. This ensures that there are no intensity peaks during the start-up phase, and also means a secure connection to the single-phase current supply even for high-output systems. This compressor start logic makes "soft start" starter devices unnecessary, at the same time guaranteeing that the maximum output is available immediately.
- **EXTERNAL COIL:**
The external coil is made of copper pipes and hydrophilic aluminium fins. This solution makes it easier for the water to move towards the bottom of the heat exchanger, by means of gravity.
In particular, this innovation means:
 - frost takes longer to form, so it doesn't build up so much on the coil;
 - the defrosting phase is more efficient thanks to improved water runoff on the fins (and this boosts operation in heating mode).Blue Coating treatment is applied as standard to improve the resistance of the coils to corrosive agents, and is recommended in all applications where there is a moderate risk of corrosion.
- **EXTERNAL FAN:**
Single DC brushless fan motor with variable speed for optimum air distribution and extremely low noise levels. The possibility to set two different maximum noise levels.

- **ELECTRONIC EXPANSION VALVE:**

The electronic expansion valve is a dual flow electronic expansion device whose job is to optimise the volume of the refrigerant fluid in the circuit and therefore the overheating issue, preventing the fluid from returning to the compressor. This device further boosts the high efficiency and reliability of the system as it enables it to work even with very low condensation pressure values across the whole operating range.

- **SOLENOID VALVE:**

Given the wide operating range of the unit, the solenoid valve (fully managed by the unit itself) allows the compressor to work at optimum temperature levels at all times.

- **PLATE HEAT EXCHANGER:**

Vertical plate heat exchanger in AISI 316 stainless steel.

- **BUILT-IN HYDRONIC UNIT:**

The hydronic module is always installed. It's supplied with a variable speed circulation pump, a flow switch, a 3 bar safety valve, an expansion tank and water temperature probes (inlet and outlet). A backup electric heater is available as an accessory. In domestic applications, there is the possibility to connect the inertial storage tank directly underneath the unit to minimise the space taken up.

All the internal hydronic parts are insulated to reduce heat loss. The anti-freeze program contains special functions that use the heat pump and backup heater (if installed) to protect the entire system from the risk of freezing. When the water flow temperature in the system falls to a certain value, the unit heats the water using both the heat pump and the electric heating tap (and also the backup heater, if installed). The anti-freeze protection function is only deactivated when the temperature rises to a certain value.



RIELLO S.p.A.
Via Ing. Pilade Riello, 7
37045 Legnago (VR)
tel. +39 0442 630111
www.riello.com

The company is constantly working to perfect its entire production range, so the design and size characteristics, technical data, equipment and accessories may vary.

RIELLO