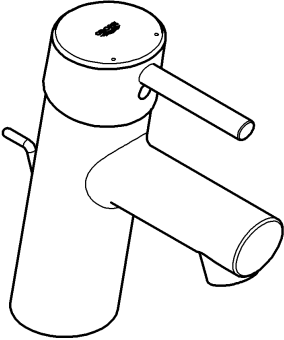
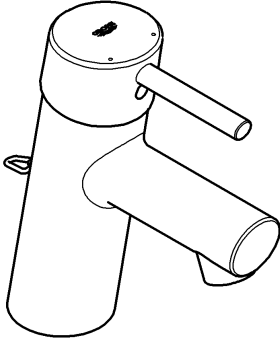
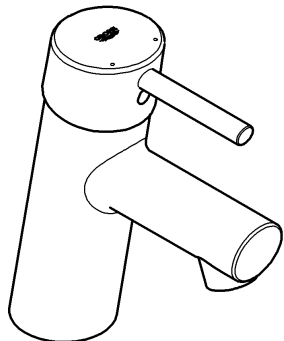
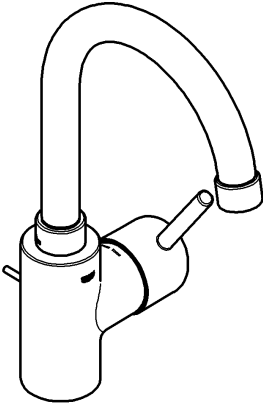
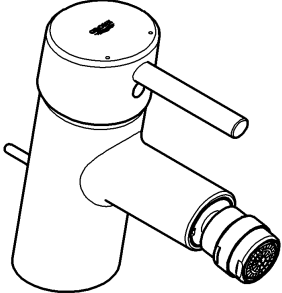
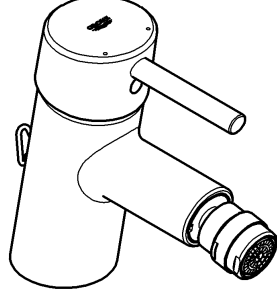

<p>32 204</p> 	<p>32 206</p> 
<p>32 240</p> 	<p>32 629</p> 
<p>32 208</p> 	<p>32 209</p> 

Concetto

Concetto

(D)1 (I)2 (N)3 (GR)5 (TR)6 (BG)7 (RO)9
 (GB)1 (NL)2 (FIN)4 (CZ)5 (SK)6 (EST)8 (CN)9
 (F)1 (S)3 (PL)4 (H)5 (SLO)7 (LV)8 (RUS)9
 (E)2 (DK)3 (UAE)4 (P)6 (HR)7 (LT)8

Design & Quality Engineering GROHE Germany

99.214.031/ÄM 218555/01.11

GROHE

 ENJOY WATER®

32 204

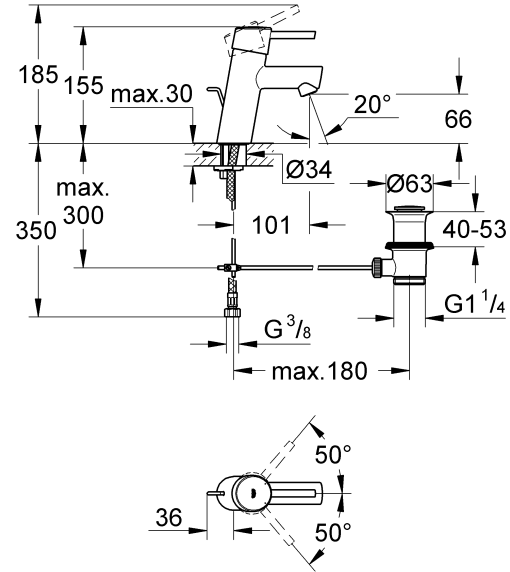

32 206

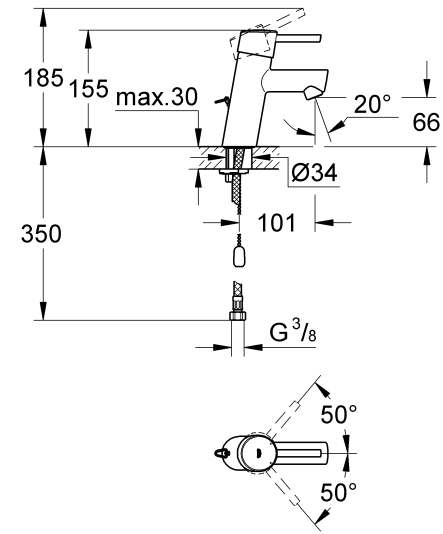

32 240

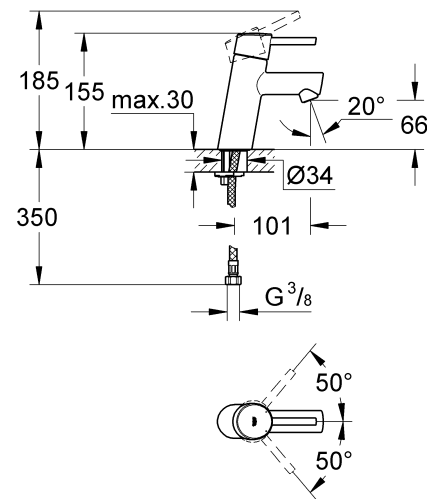

32 629

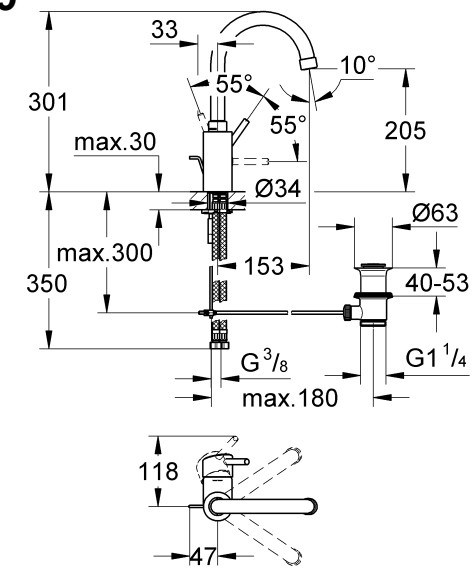

32 208

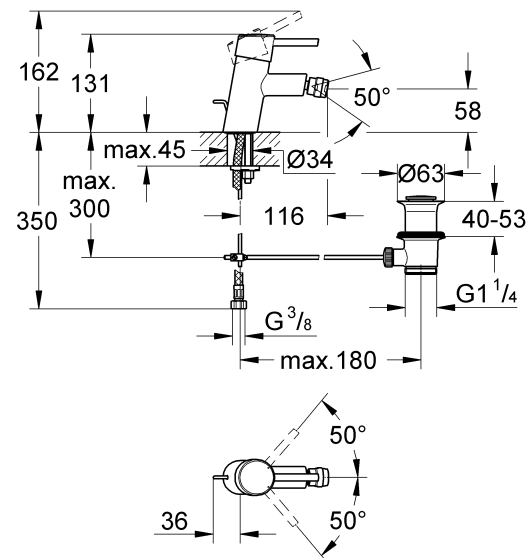

32 209

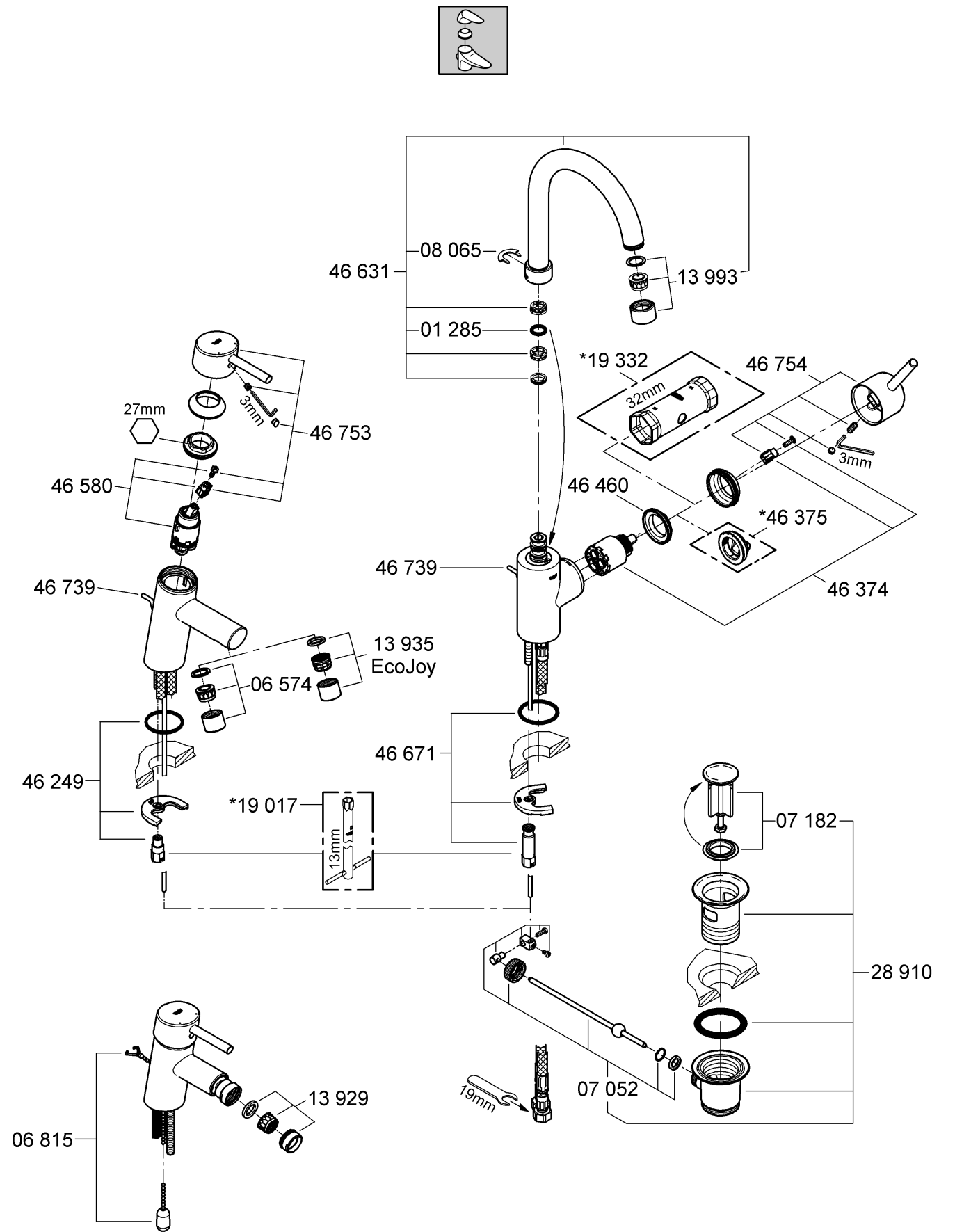
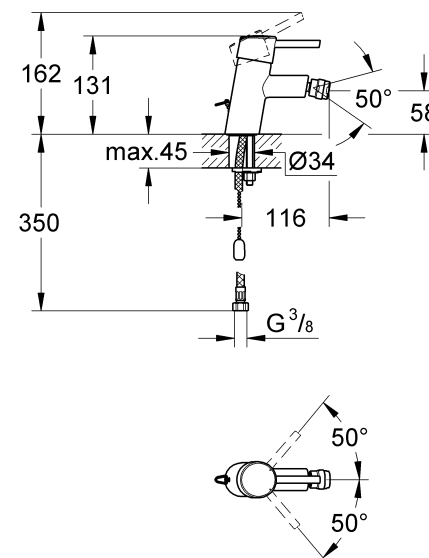

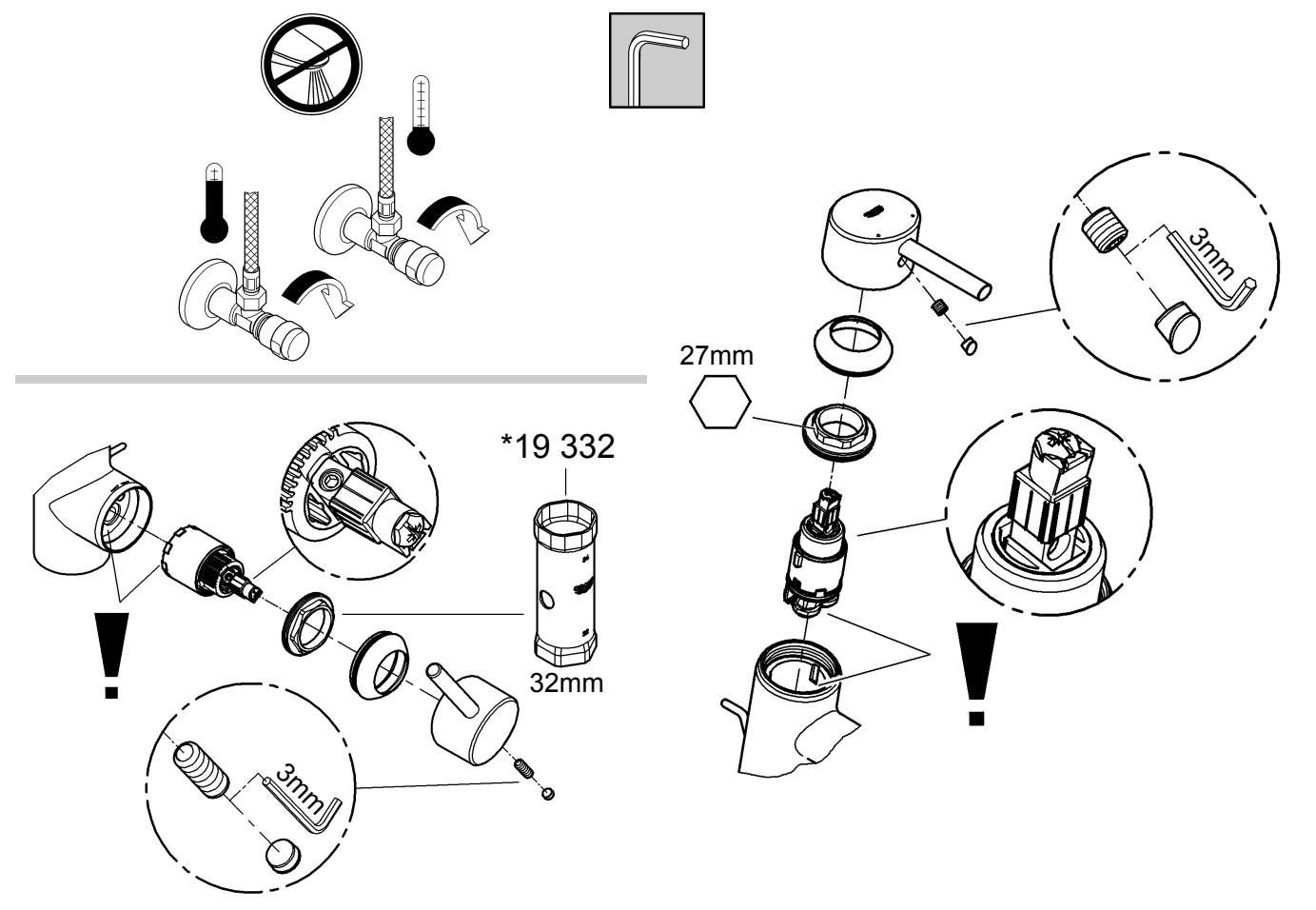
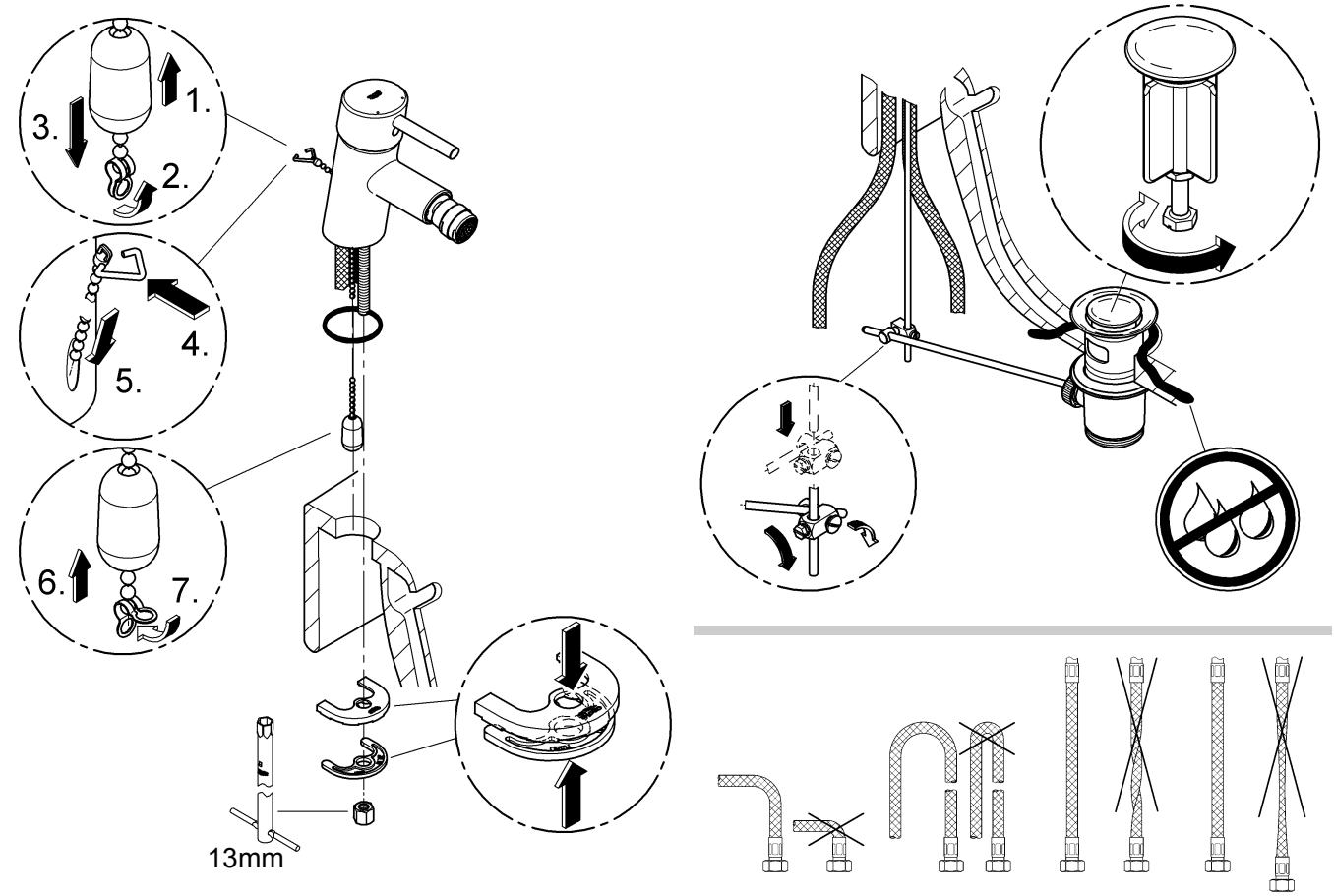
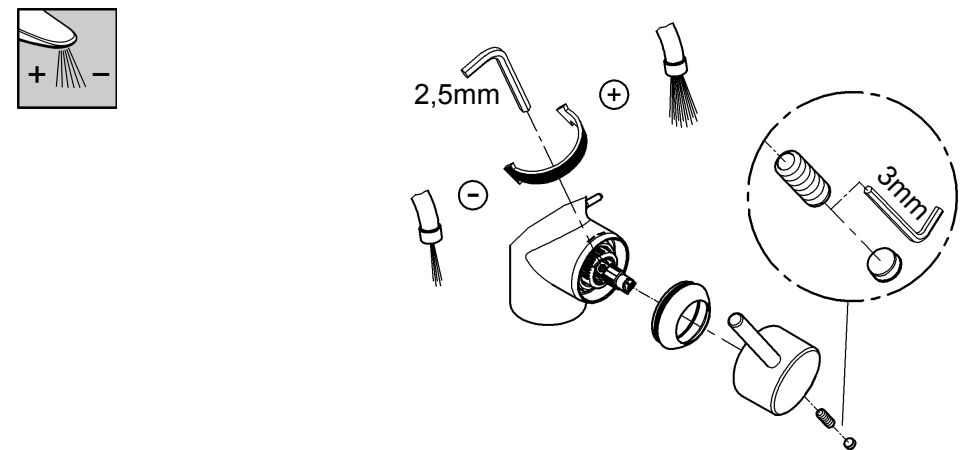
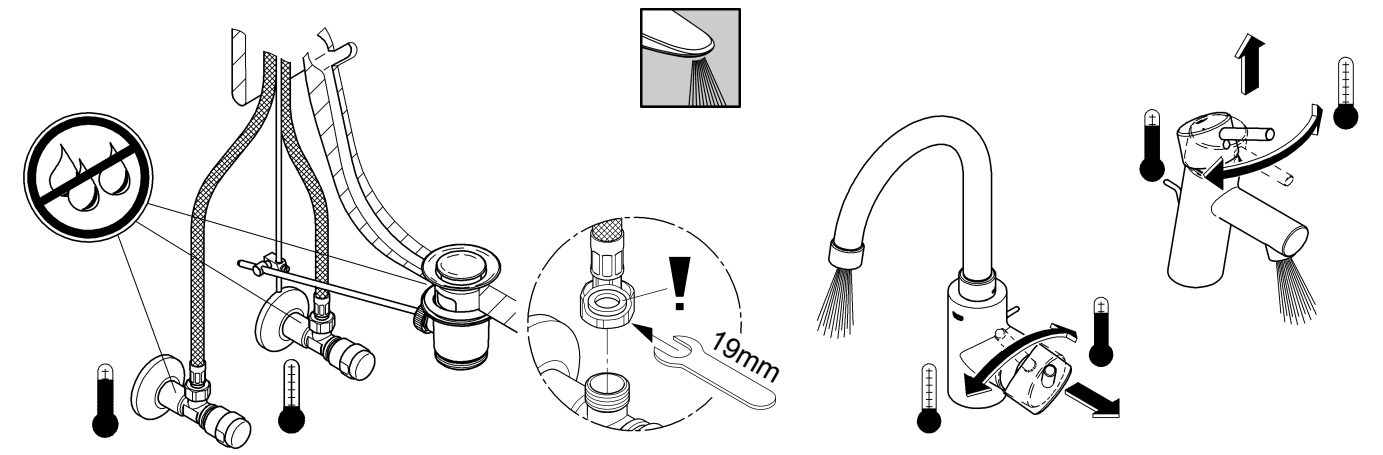
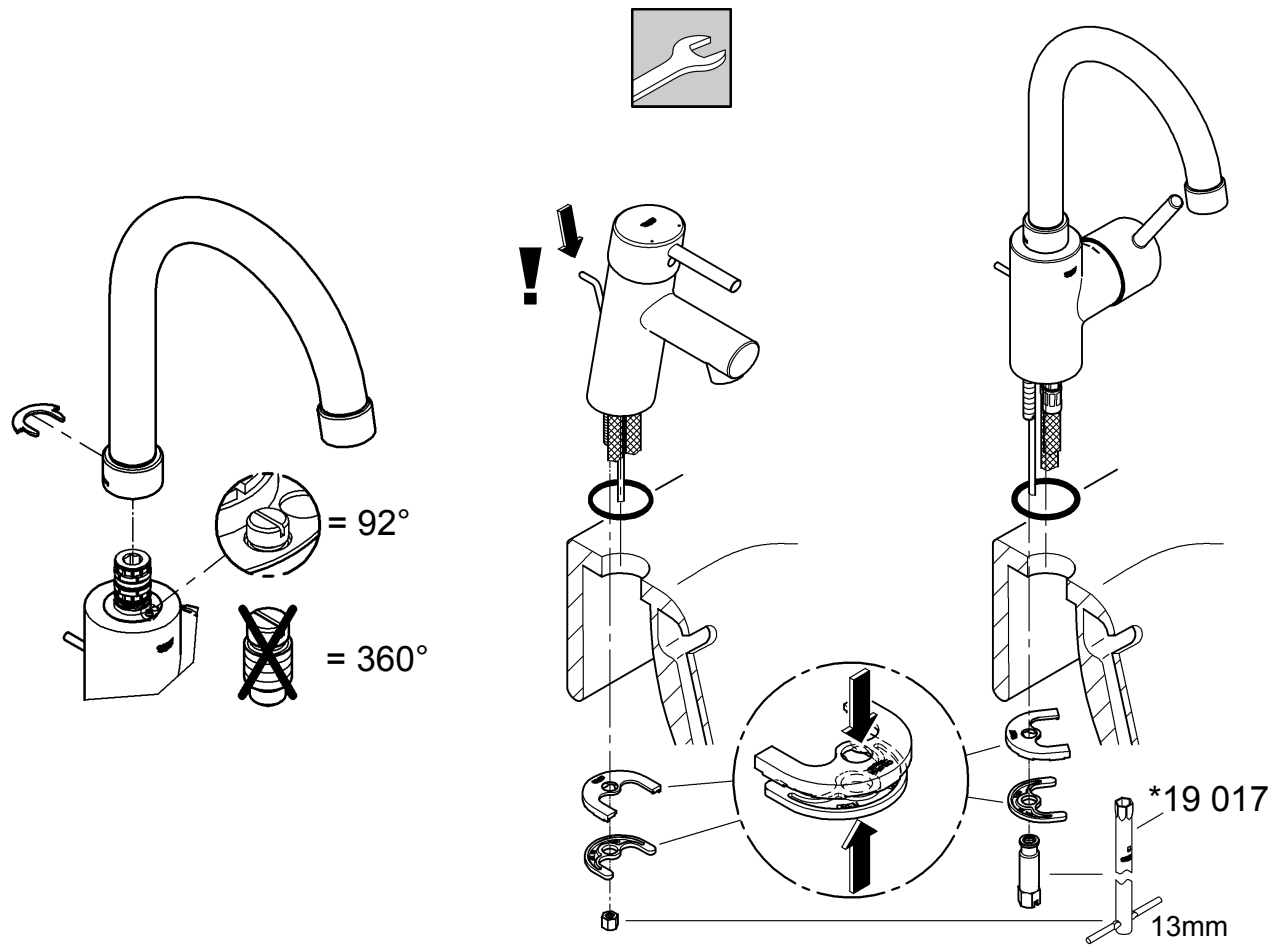



**Diese Technische Produktinformation ist ausschließlich für den Installateur oder eingewiesene Fachkräfte!
Bitte an den Benutzer weitergeben!**

Anwendungsbereich:

Der Betrieb mit drucklosen Speichern (offenen Warmwasserbereitern) ist **nicht** möglich.

Technische Daten

Fließdruck:	min. 0,5 bar – empfohlen 1 – 5 bar	
Betriebsdruck:	max. 10 bar	
Prüfdruck:	16 bar	
Durchfluss bei 3 bar Fließdruck		
bei Waschtisch:	9 l/min EcoJoy: 5 l/min	32 629: 12 l/min
bei Bidet:	9 l/min	
Temperatur Warmwassereingang	max. 80 °C	
Empfohlen (Energieeinsparung):	60 °C	

Zur Einhaltung der Geräuschwerte nach DIN 4109 ist bei Ruhedrücken über 5 bar ein Druckminderer einzubauen. Höhere Druckdifferenzen zwischen Kalt- und Warmwasseranschluss sind zu vermeiden!



Installation:

Rohrleitungssystem vor und nach der Installation gründlich spülen (DIN 1988/DIN EN 806 beachten)!
32 629: Einbau eines Temperaturbegrenzers möglich (Best.-Nr. 46 375).



Funktion:

Anschlüsse auf Dichtheit und Armatur auf Funktion prüfen.



Mengenbegrenzung:

In Verbindung mit hydraulischen Durchlauferhitzern ist eine Durchflussmengenbegrenzung nicht zu empfehlen.



Wartung:

Alle Teile prüfen, reinigen, evtl. austauschen.
Bei Wartungsarbeiten Wasserzufuhr absperren!



Beim Einbau der Kartusche auf richtigen Sitz der Dichtungen achten.

Verschraubung einschrauben und fest anziehen.



Ersatzteile: siehe Explosionsdarstellung (* = Sonderzubehör)

Pflege: siehe Pflegeanleitung



**This technical product information is exclusively for the installer or trained specialists.
Please pass these instructions on to the user.**

Application:

Operation with unpressurised storage heaters is **not** possible.

Specifications

Flow pressure:	min. 0.5 bar – recommended 1 – 5 bar	
Operating pressure:	max. 10 bar	
Test pressure:	16 bar	
Flow rate at 3 bar flow pressure:		
for wash basin:	9 l/min EcoJoy: 5 l/min	32 629: 12 l/min
for bidet mixer:	9 l/min	
Hot water inlet temperature	max. 80 °C	
Recommended (energy saving):	60 °C	

If static pressure exceeds 5 bar, a pressure-reducing valve must be fitted.
Avoid major pressure differences between hot and cold water supply.



Installation:

Flush piping system prior and after installation of fitting thoroughly (Consider EN 806)!
32 629: Fitting a temperature limiter is possible (Prod. no. 46 375).



Function:

Check connections for leaks and check function of fitting.



Flow rate limitation:

The use of flow rate limiters in combination with hydraulic instantaneous heaters is not recommended.



Maintenance:

Inspect and clean all components and replace if necessary.
Shut off water supply for maintenance work.



When installing the cartridge, ensure that the seals are correctly seated.

Screw in and tighten screwing.



Replacement parts: see exploded drawing (* = special accessories)

Care: see Care Instructions



**La documentation technique/produit est exclusivement destinée aux plombiers et aux personnels qualifiés.
Penser à la remettre à l'utilisateur.**

Domaine d'application:

Un fonctionnement avec des accumulateurs sans pression (chauffe-eau à écoulement libre) n'est **pas possible!**

Caractéristiques techniques

Pression dynamique:	minimale 0,5 bar – recommandée 1 à 5 bars	
Pression de service:	10 bars maxi.	
Pression d'épreuve:	16 bars	
Débit à une pression dynamique de 3 bars:		
lavabo:	9 l/min EcoJoy: 5 l/min	32 629: 12 l/min
bidet:	9 l/min	
Température de l'eau chaude	80 °C maxi.	
Recommandée (économie d'énergie):	60 °C	

Installer un réducteur de pression en cas de pressions statiques supérieures à 5 bars. Eviter les différences importantes de pression entre les raccordements d'eau chaude et d'eau froide!



Installation

Bien rincer les canalisations avant et après l'installation (respecter la norme EN 806)!
32 629: Possibilité de montage d'un limiteur de température (réf. 46 375).



Fonctionnement

Contrôler l'étanchéité des raccordements et contrôler le fonctionnement de la robinetterie.



Limiteur de débit

La limitation du débit est déconseillée avec des chauffe-eau instantanés à commande hydraulique.



Maintenance

Contrôler et nettoyer toutes les pièces, les remplacer le cas échéant.

Fermer les arrivées d'eau en cas de maintenance.



Contrôler le siège des joints lors du montage de la cartouche.

Insérer la bague filetée et serrer jusqu'au blocage.



Pièces de rechange voir vue explosée (* = accessoires spéciaux).

Entretien: voir les instructions d'entretien



¡Esta información técnica de productos está destinada exclusivamente para el instalador o profesionales del sector!

¡Por favor, entréguesela al usuario!

Campo de aplicación

No es posible el funcionamiento con acumuladores sin presión (calentadores de agua sin presión).

Datos técnicos

Presión de trabajo: mín. 0,5 bares – recomendada 1 – 5 bares

Presión de utilización: máx. 10 bares

Presión de verificación: 16 bares

Caudal para una presión de trabajo de 3 bares:

batería de lavabo: 9 l/min EcoJoy: 5 l/min **32 629**: 12 l/min

batería de bidé: 9 l/min

Temperatura de la entrada del agua caliente máx. 80 °C

Recomendada (ahorro de energía): 60 °C

Si la presión en reposo es superior a 5 bares, hay que instalar un reductor de presión.

¡Deberán evitarse diferencias de presión importantes entre las acometidas del agua fría y del agua caliente!



Instalación:

¡Purgar a fondo el sistema de tuberías antes y después de la instalación (tener en cuenta EN 806)!

32 629: Es posible el montaje de un limitador de temperatura (Núm. de pedido 46 375).



Funcionamiento:

Comprobar la estanqueidad de las conexiones y el funcionamiento de la grifería.



Limitación del caudal:

Se recomienda no utilizar el limitador de caudal en combinación con calentadores instantáneos con control hidráulico.



Mantenimiento:

Verificar todas las piezas, limpiarlas y cambiarlas en caso de necesidad.

¡Cerrar la alimentación de agua al realizar trabajos de mantenimiento!



Al montar el cartucho tener en cuenta el correcto asiento de las juntas. Enroscar la unión atornillada y apretar fuertemente.



Recambios: véase la vista de despiece

(* = Accesorio especial)

Cuidados: véanse las instrucciones de conservación



Queste informazioni tecniche sul prodotto sono ad uso esclusivo dell'installatore e di personale qualificato!

Si prega di consegnarle all'utente!

Gamma di applicazioni:

Non è possibile il funzionamento con accumulatori di acqua calda a bassa pressione (accumulatori di acqua calda a circuito aperto).

Dati tecnici

Pressione idraulica min. 0,5 bar – consigliata 1 – 5 bar

Pressione di esercizio max. 10 bar

Pressione di prova 16 bar

Portata alla pressione di 3 bar:

con rubinetto lavabo: 9 l/min EcoJoy: 5 l/min **32 629**: 12 l/min

con miscelatore bidet: 9 l/min

Temperatura ingresso acqua calda: max. 80 °C

Consigliata (risparmio energetico): 60 °C

Per pressioni statiche superiori a 5 bar si raccomanda l'installazione di un riduttore di pressione.

Evitare grandi differenze di pressione fra i raccordi d'acqua fredda e d'acqua calda!



Installazione:

Prima e dopo l'installazione pulire a fondo il sistema di tubazioni (osservare la norma EN 806)!

32 629: E' possibile montare un apposito limitatore di temperatura (n. di codice 46 375).



Funzionamento:

Controllare la tenuta dei raccordi e il funzionamento del rubinetto.



Limitatore di portata:

L'uso di un limitatore di portata non è consigliabile con scaldabagni istantanei idraulici.



Manutenzione:

Controllare, pulire ed eventualmente sostituire tutti i pezzi.

Chiudere l'entrata dell'acqua durante i lavori di manutenzione!



Durante il montaggio della cartuccia controllare che le guarnizioni siano perfettamente in sede.

Avvitare il raccordo a vite e serrarlo bene.



Pezzi di ricambio: vedi immagini esplose

(* = accessori speciali).

Manutenzione ordinaria: vedi istruzioni per manutenzione ordinaria



Deze technische productgegevens zijn uitsluitend bedoeld voor de installateur of gekwalificeerde monteurs!

Overhandig deze aan de gebruiker!

Toepassingsgebied:

Het werken met lagedrukboilers (open warmwatertoestellen) is niet mogelijk!

Technische gegevens

Stromingsdruk: min. 0,5 bar – aanbevolen 1 – 5 bar

Werkdruk: max. 10 bar

Testdruk: 16 bar

Capaciteit bij 3 bar stromingsdruk:

bij wastafelmengkraan: 9 l/min EcoJoy: 5 l/min **32 629**: 12 l/min

bij bidetmengkraan: 9 l/min

Temperatuur warmwateringang max. 80 °C

Aanbevolen (energiebesparing): 60 °C

Bij statische drukken boven 5 bar dient een drukreducerend ventiel te worden ingebouwd. Voorkom hoge drukverschillen tussen de koud- en warmwateraansluiting!



Installeren:

Leidingen vóór en na het installeren grondig spoelen (EN 806 in acht nemen)!

32 629: Inbouwen van een temperatuurbegrenzer mogelijk (best. nr. 46 375).



Werking:

Controleer of de aansluitingen niet lekken en of de kraan werkt.



Volumebegrenzer:

In combinatie met c.v.-ketels met warmwatervoorziening en geisers is een doorstroombeperking aan de warmwaterkant niet aan te raden, i.v.m. de tapdrempel van de geiser/combiketel.



Onderhoud:

Controleer alle onderdelen, reinig en vervang deze indien nodig.

Sluit bij onderhoudswerkzaamheden de watertoevoer af!



Controleer bij het inbouwen van de kardoos of de afdichtingen goed zitten.

Breng de schroefring aan en draai deze stevig vast.



Reserveonderdelen: zie stuklijst

(* = speciaal toebehoren)

Reiniging: zie reinigingsaanwijzing

D

Grohe Deutschland
Vertriebs GmbH
Zur Porta 9
32457 Porta Westfalica
Tel.: +49 571 3989-333
Fax: +49 571 3989-999

A

GROHE Ges.m.b.H.
Wienerbergstraße 11/A7
1100 Wien
Tel.: +43 1 68060
Fax: +43 1 6884535

B

GROHE nv - sa
Diependaalweg 4a
3020 Winksele
Tel.: +32 16 230660
Fax: +32 16 239070

BG

Търговско представителство
Grohe AG България
Бизнес център Слатина
Ул. Слатинска 1
1574 София
Тел. : +359 2 9719959
+359 2 9712535
Факс.: +359 2 9712422

CDN

GROHE Canada Inc.
1230 Lakeshore Road East
Mississauga, Ontario
Canada, L5E 1E9
Tel.: +1 905 2712929
Fax: +1 905 2719494

CH

Grohe Switzerland SA
Oberfeldstrasse 14
8302 Klotten
Tel.: +41 44 8777300
Fax: +41 44 8777320

CN

高仪 (上海)
卫生洁具有限公司
上海市黄陂北路227号
中区广场607-610室
电话: +86 21 63758878
传真: +86 21 63758665

CY

GROME Marketing (Cyprus) Ltd.
195B, Old Nicosia-Limassol Road
Dhali Industrial Zone
P.O. Box 27048
1641 Nicosia
Tel.: +357 22 465200
Fax: +357 22 379188

CZ SK

Grohe ČR s.r.o.
Zastoupení pro ČR a SR
V Oblouku 104, Čestlice
252 43 Průhonice
Tel.: +420 22509 1082
Fax: +420 22509 1085

DK

GROHE A/S
Walgerholm 11
3500 Vaerløse
Tel.: +45 44 656800
Fax: +45 44 650252

E

GROHE España S.A.
C/ Botanica, 78 - 88
Gran Via L'H - Distr. Econòmic
08908 L'Hospitalet de Llobregat
(Barcelona)
Tel.: +34 93 3368850
Fax: +34 93 3368851

EST LT LV

GROHE AG Eesti filiaal
Tartu mnt 16
10117 Tallinn
Tel.: +372 6616354
Fax: +372 6616364

F

GROHE s.à.r.l.
60, Boulevard de la Mission
Marchand
92400 Courbevoie - La Défense
Tel.: +33 1 49972900
Fax: +33 1 55702038

FIN

Oy Teknocalor Ab
Sinikellonkuja 4
01300 Vantaa
Tel.: +358 9 8254600
Fax: +358 9 826151

GB

GROHE Limited
Blays House, Wick Road
Englefield Green
Egham, Surrey, TW20 0HJ
Tel.: +44 871 200 3414
Fax: +44 871 200 3415

GR

N. Sapountzis S.A.
86, Kapodistriou & Roumelis Str.
142 35 N. Ionia - Athens
Tel.: +30 210 2712908
Fax: +30 210 2715608

H

GROHE Hungary Kft.
Röppentyű u. 53.
1139 Budapest
Tel.: +36 1 238 80 45
Fax: +36 1 238 07 13

HR

GROHE AG - Predstavništvo
Štefanovečka 10
10000 Zagreb
Tel.: +385 1 2989025
Fax: +385 1 2910962

I

GROHE S.p.A.
Via Castellazzo Nr. 9/B
20040 Cambiagio (Milano)
Tel.: +39 2 959401
Fax: +39 2 95940263

IND

Grohe India Private Limited
The Great Eastern Centre
Gesco Corporate Centre
70 Nehru Place
New Dehli 110019
Tel.: +91 11 5561 9423 / 9513
Fax: +91 11 5561 9451

IS

BYKO hf.
Skemmuvegi 2
200 Kópavogur
Tel.: +354 515 4000
Fax: +354 515 4099

J

Grohe Japan Ltd.
TRC Building, 3F
1-1 Heiwajima 6-chome, Ota-ku
Tokyo 143-0006
Tel.: +81 3 32989730
Fax: +81 3 37673811

N

GROHE A/S
Nils Hansens vei 20
0667 Oslo
Tel.: +47 22 072070
Fax: +47 22 072071

NL

GROHE Nederland BV
Metaalstraat 2
2718 SW Zoetermeer
Tel.: +31 79 3680133
Fax: +31 79 3615129

P

GROHE Portugal
Componentes Sanitários, Lda.
Rua Arq. Cassiano Barbosa, 539
1.º Frente Esquerdo
4100-009 Porto
Tel.: +351 22 543 29 80
Fax: +351 22 543 29 99

PL

GROHE Polska Sp. z o.o.
Pulawska 182 Street
02-670 Warszawa
Tel.: +48 22 5432 640
Fax: +48 22 5432 650

RUS

Представительство
Grohe AG
Москва, ул. Пусаковская 13, стр.1
1107140
тел.: +7 495 9819510
факс: +7 495 9819511

RO

Grohe AG Reprezentanta
Strada Nicolae Iorga 13,
Corp B
010432 Bucuresti (Sector 1)
Tel.: +40 21 2125050
Fax: +40 21 2125048

S

GROHE A/S
Kungsängsvägen 25
753 23 Uppsala
Tel.: +46 771 141314
Fax: +46 771 141315

SLO

GROSAN inženiring d.o.o.
Slandrova 4
1000 Ljubljana
Tel.: +386 1 5633060
Fax: +386 1 5633061

TR

GROME İc ve Dis Ticaret Ltd. Sti.
Bagdat Cad. Ugras Parlar Is
Merkezi No: 605, B Blok D: 12 - 15
34846 Cevizli - Maltepe-Istanbul
Tel.: +90 216 4412370
Fax: +90 216 3706174

UA

Представництво
Grohe AG в Україні
Вул. Івана Франка, 18-А
01030 Київ
тел. : +38 044 537 52 73
факс: +38 044 590 01 96

USA

GROHE America Inc.
241 Covington Drive
Bloomington
Illinois, 60108
Tel.: +1 630 5827711
Fax: +1 630 5827722

**Eastern Mediterranean
Middle East - Africa
Area Sales Office:**
GROME Marketing (Cyprus) Ltd.
195B, Old Nicosia-Limassol Road
Dhali Industrial Zone
P.O. Box 27048
1641 Nicosia
Tel.: +357 22 465200
Fax: +357 22 379188

Far East Area Sales Office:
GROHE Pacific Pte. Ltd.
438 Alexandra Road
06-01/04 Alexandra Point
Singapore 119958
Tel.: +65 6376 4500
Fax: +65 6378 0855

www.grohe.com

GROHE
ENJOY WATER®